



Product Specification

AU OPTRONICS CORPORATION

(V) Preliminary Specifications

() Final Specifications

Module	17.3" HD+ Color TFT-LCD with LED Backlight design
Model Name	B173RW01 V1 (H/W:0A)
Note ()	<i>LED Backlight with driving circuit design</i>

Customer	Date
Checked & Approved by	Date
_____	_____

Note: This Specification is subject to change without notice.

Approved by	Date
Prepared by	
_____	_____

NBBU Marketing Division / AU Optronics corporation

Contents

1. Handling Precautions	3
2. General Description	3
2.1 General Specification	3
2.2 Optical Characteristics	3
3. Functional Block Diagram	3
4. Absolute Maximum Ratings.....	3
4.1 Absolute Ratings of TFT LCD Module	3
4.2 Absolute Ratings of Environment	3
5. Electrical characteristics	3
5.1 TFT LCD Module.....	3
5.2 Backlight Unit	3
6. Signal Characteristic	3
6.1 Pixel Format Image	3
6.2 The input data format	3
6.3 Integration Interface and Pin Assignment.....	3
6.4 Interface Timing	3
7. Connector Description.....	3
7.1 TFT LCD Module.....	3
8. LED Driving Specification	3
8.1 Connector Description.....	3
8.2 Pin Assignment.....	3
9. Vibration and Shock Test	3
9.1 Vibration Test	3
9.2 Shock Test Spec:.....	3
10. Reliability.....	3
11. Mechanical Characteristics.....	3
11.1 LCM Outline Dimension	3
11.2 Screw Hole Depth and Center Position	3
12. Shipping and Package.....	3
12.1 Shipping Label Format	3
12.2 Carton package	3
12.3 Shipping package of palletizing sequence.....	3
13. Appendix: EDID description	3



Product Specification

AU OPTRONICS CORPORATION

Record of Revision

Version and Date	Page	Old description	New Description	Remark
0.1 2008/08/07	All	First Edition for Customer		
0.2 2008/09/03	34-37		Add EDID	

1. Handling Precautions

- 1) Since front polarizer is easily damaged, pay attention not to scratch it.
- 2) Be sure to turn off power supply when inserting or disconnecting from input connector.
- 3) Wipe off water drop immediately. Long contact with water may cause discoloration or spots.
- 4) When the panel surface is soiled, wipe it with absorbent cotton or other soft cloth.
- 5) Since the panel is made of glass, it may break or crack if dropped or bumped on hard surface.
- 6) Since CMOS LSI is used in this module, take care of static electricity and insure human earth when handling.
- 7) Do not open nor modify the Module Assembly.
- 8) Do not press the reflector sheet at the back of the module to any directions.
- 9) At the insertion or removal of the Signal Interface Connector, be sure not to rotate nor tilt the Interface Connector of the TFT Module.
- 11) After installation of the TFT Module into an enclosure (Notebook PC Bezel, for example), do not twist nor bend the TFT Module even momentary. At designing the enclosure, it should be taken into consideration that no bending/twisting forces are applied to the TFT Module from outside. Otherwise the TFT Module may be damaged.
- 12) Small amount of materials having no flammability grade is used in the LCD module. The LCD module should be supplied by power complied with requirements of Limited Power Source (IEC60950 or UL1950), or be applied exemption.
- 13) Disconnecting power supply before handling LCD modules, it can prevent electric shock, DO NOT TOUCH the electrode parts, cables, connectors and LED circuit part of TFT module that a LED light bar build in as a light source of back light unit. It can prevent electronic breakdown.



2. General Description

B173RW01 V1 is a Color Active Matrix Liquid Crystal Display composed of a TFT LCD panel, a driver circuit, and LED backlight system. The screen format is intended to support the HD+ (1600(H) x 900(V)) screen and 262k colors (RGB 6-bits data driver) with LED backlight driving circuit. All input signals are LVDS interface compatible.

B173RW01 V1 is designed for a display unit of notebook style personal computer and industrial machine.

2.1 General Specification

The following items are characteristics summary on the table at 25 °C condition:

Items	Unit	Specifications			
Screen Diagonal	[mm]	438.38(17.3W")			
Active Area	[mm]	382.08 X 214.92			
Pixels H x V		1600 x 3(RGB) x 900			
Pixel Pitch	[mm]	0.2388X0.2388			
Pixel Format		R.G.B. Vertical Stripe			
Display Mode		Normally White			
White Luminance (ILED=20mA) (Note: ILED is LED current)	[cd/m ²]	200 typ. (5 points average) 170 min. (5 points average)			
Luminance Uniformity		1.25 max. (5 points)			
Contrast Ratio		500 typ			
Response Time	[ms]	8 typ / 16 Max			
Nominal Input Voltage VDD	[Volt]	+3.3 typ.			
Power Consumption	[Watt]	TBD max. (Include Logic and Blu power)			
Weight	[Grams]	570 max.			
Physical Size without inverter, bracket.	[mm]		Min.	Typ.	Max.
		Length	397.6	398.1	398.6
		Width	232.3	232.8	233.3
		Thickness	-	-	6.0
Electrical Interface		2 channel LVDS			
Surface Treatment		AG, Hardness 3H,			
Support Color		262K colors (RGB 6-bit)			



Product Specification

AU OPTRONICS CORPORATION

Temperature Range Operating	[°C]	0 to +50
Storage (Non-Operating)	[°C]	-20 to +60
RoHS Compliance		RoHS Compliance

2.2 Optical Characteristics

The optical characteristics are measured under stable conditions at 25°C (Room Temperature) :

Item	Symbol	Conditions	Min.	Typ.	Max.	Unit	Note
White Luminance $I_{LED=20mA}$		5 points average	187	220	-	cd/m ²	1, 4, 5.
Viewing Angle	θ_R	Horizontal (Right) CR = 10 (Left)	40	45	-	degree	4, 9
	θ_L		40	45	-		
	ϕ_H	Vertical (Upper) CR = 10 (Lower)	10	15	-		
	ϕ_L		30	35	-		
Luminance Uniformity	δ_{5P}	5 Points	-	-	1.25		1, 3, 4
Luminance Uniformity	δ_{13P}	13 Points	-	-	1.50		2, 3, 4
Contrast Ratio	CR		400	500	-		4, 6
Cross talk	%				4		4, 7
Response Time	T_r	Rising	-	TBD	-	msec	4, 8
	T_f	Falling	-	TBD	-		
	T_{RT}	Rising + Falling	-	8	16		
Color / Chromaticity Coordinates	Red	Rx	-	TBD	-	CIE 1931	4
		Ry	-	TBD	-		
	Green	Gx	-	TBD	-		
		Gy	-	TBD	-		
	Blue	Bx	-	TBD	-		
		By	-	TBD	-		
	White	Wx	0.283	0.313	0.343		
		Wy	0.299	0.329	0.359		
NTSC	%		-	60	-		

Note 1: 5 points position (Ref: Active area)

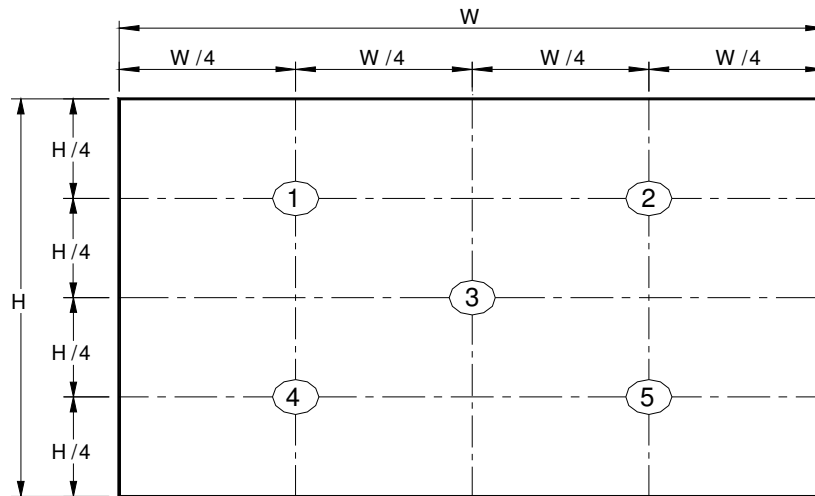

Note 2: 13 points position (Ref: Active area)

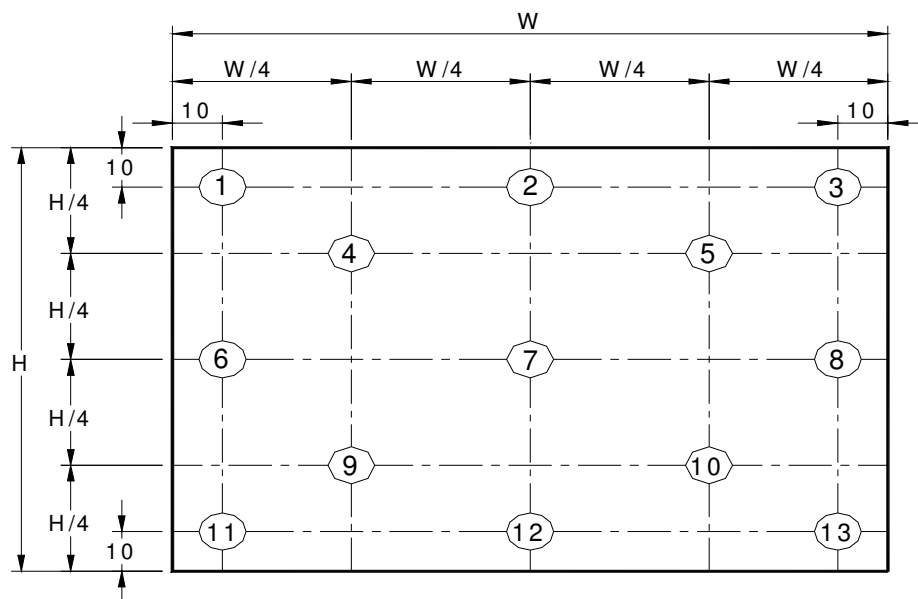

Note 3: The luminance uniformity of 5 or 13 points is defined by dividing the maximum luminance values by the minimum test point luminance

$$\delta_{w5} = \frac{\text{Maximum Brightness of five points}}{\text{Minimum Brightness of five points}}$$

$$\delta_{w13} = \frac{\text{Maximum Brightness of thirteen points}}{\text{Minimum Brightness of thirteen points}}$$

Note 4: Measurement method

The LCD module should be stabilized at given temperature for 30 minutes to avoid abrupt temperature change during measuring. In order to stabilize the luminance, the measurement should be executed after lighting

Backlight for 30 minutes in a stable, windless and dark room, and it should be measured in the center of screen.

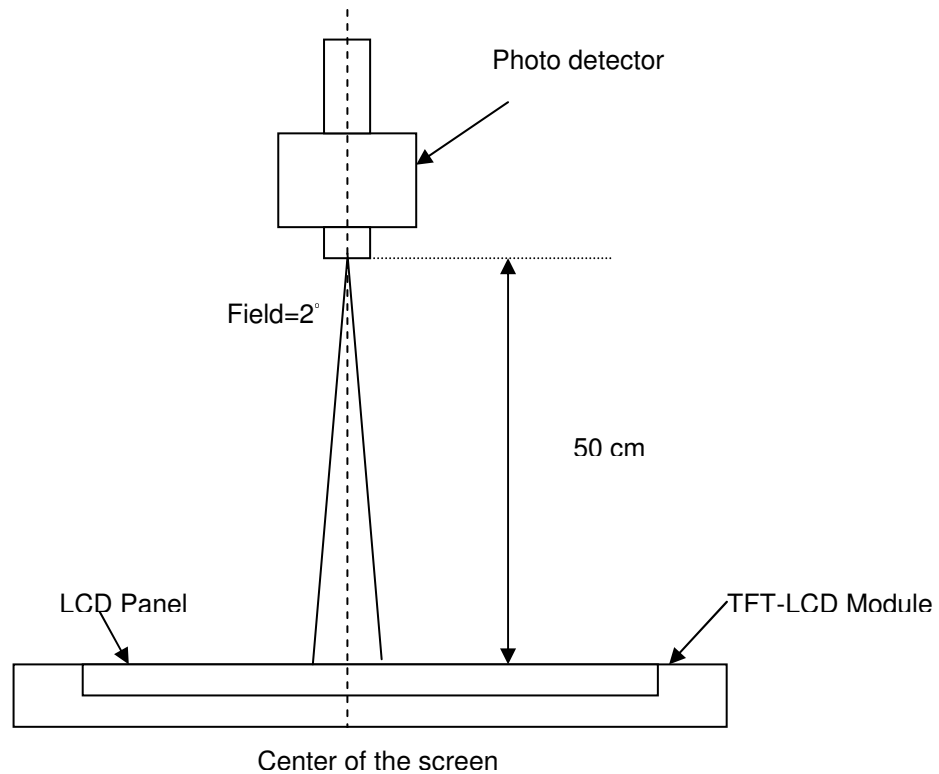

Note 5 : Definition of Average Luminance of White (Y_L):

Measure the luminance of gray level 63 at 5 points · $Y_L = [L(1) + L(2) + L(3) + L(4) + L(5)] / 5$

$L(x)$ is corresponding to the luminance of the point X at Figure in Note (1).

Note 6 : Definition of contrast ratio:

Contrast ratio is calculated with the following formula.

$$\text{Contrast ratio (CR)} = \frac{\text{Brightness on the "White" state}}{\text{Brightness on the "Black" state}}$$

Note 7 : Definition of Cross Talk (CT)

$$CT = |Y_B - Y_A| / Y_A \times 100 (\%)$$

Where

Y_A = Luminance of measured location without gray level 0 pattern (cd/m^2)

Y_B = Luminance of measured location with gray level 0 pattern (cd/m^2)

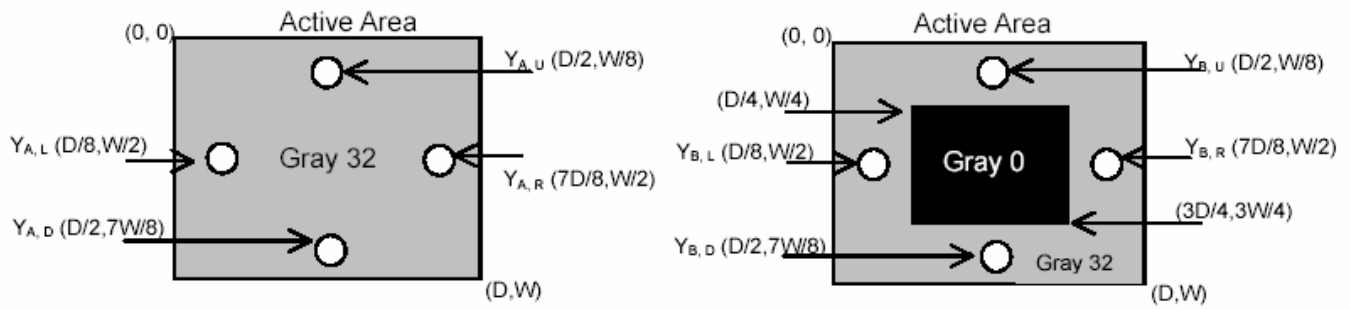

Note 8: Definition of response time:

The output signals of BM-7 or equivalent are measured when the input signals are changed from "Black" to "White" (falling time) and from "White" to "Black" (rising time), respectively. The response time interval between the 10% and 90% of amplitudes. Refer to figure as below.

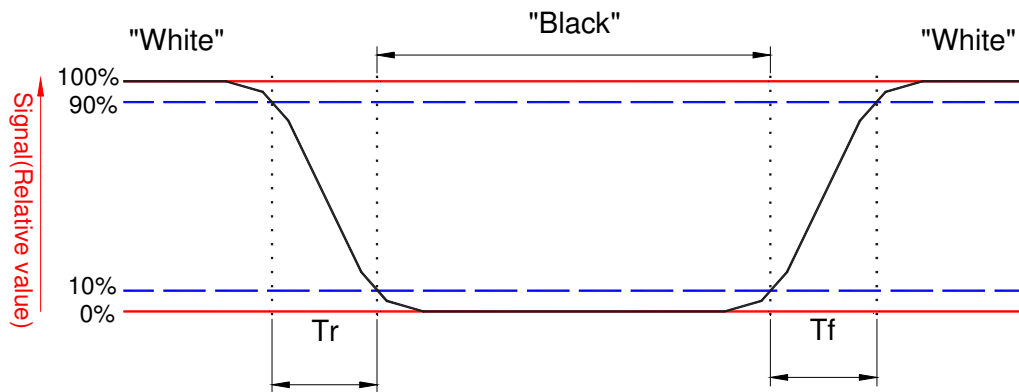

Note 9. Definition of viewing angle

Viewing angle is the measurement of contrast ratio ≥ 10 , at the screen center, over a 180° horizontal and 180° vertical range (off-normal viewing angles). The 180° viewing angle range is broken down as follows; 90° (θ) horizontal left and right and 90° (ϕ) vertical, high (up) and low (down). The measurement direction is typically perpendicular to the display surface with the screen rotated about its center to develop the desired measurement viewing angle.

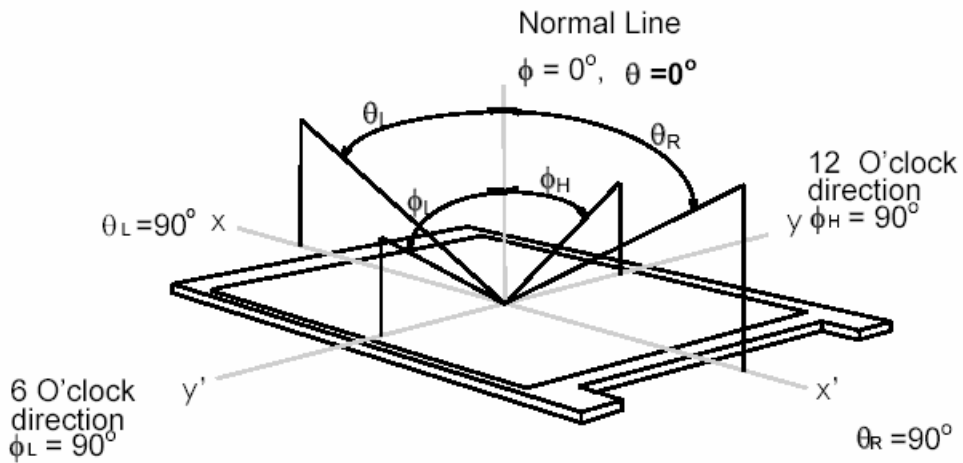

3. Functional Block Diagram

The following diagram shows the functional block of the 17.3 inches wide Color TFT/LCD 40 Pin (One CH/connector Module)

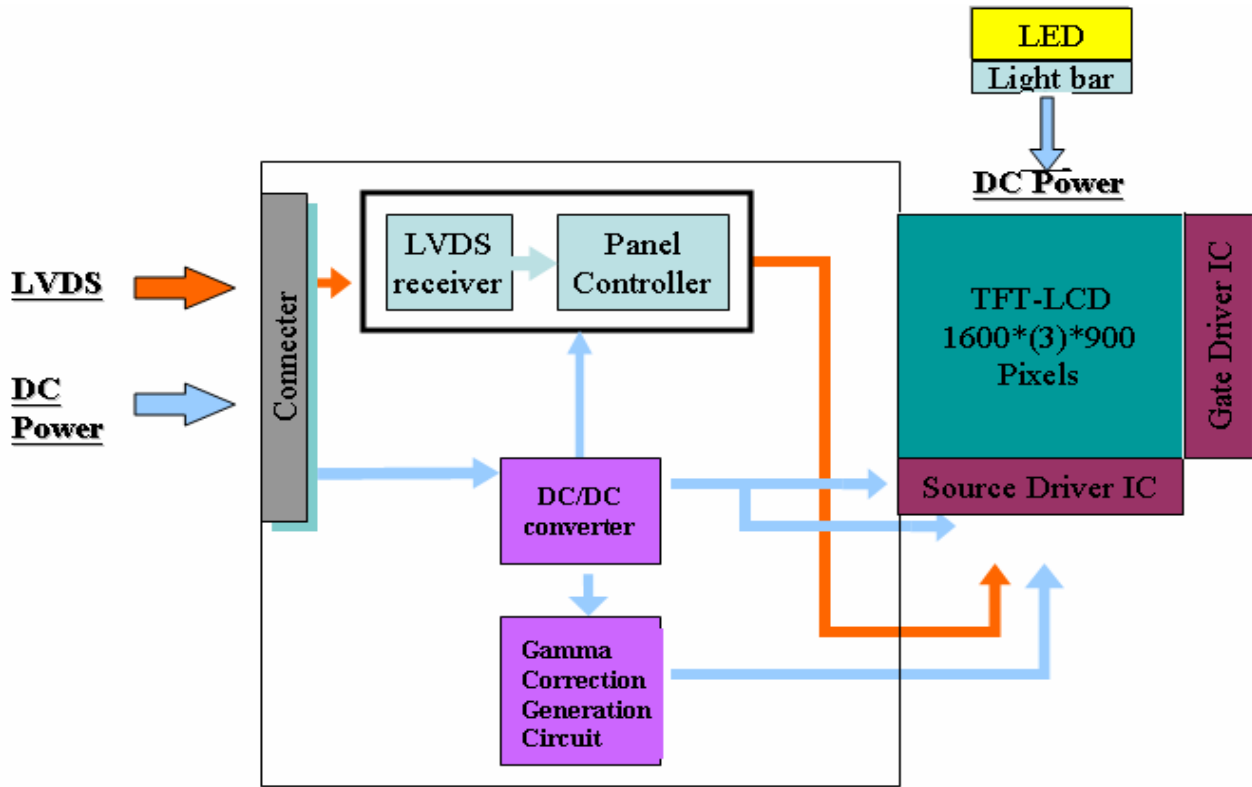

4. Absolute Maximum Ratings

An absolute maximum rating of the module is as following:

4.1 Absolute Ratings of TFT LCD Module

Item	Symbol	Min	Max	Unit	Conditions
Logic/LCD Drive Voltage	Vin	-0.3	+4.0	[Volt]	Note 1,2

4.2 Absolute Ratings of Environment

Item	Symbol	Min	Max	Unit	Conditions
Operating Temperature	TOP	0	+50	[°C]	Note 4
Operation Humidity	HOP	10	90	[%RH]	Note 4
Storage Temperature	TST	-20	+60	[°C]	Note 4
Storage Humidity	HST	10	90	[%RH]	Note 4

Note 1: At Ta (25°C)

Note 2: Permanent damage to the device may occur if exceed maximum values

Note 3: LED specification refer to section 5.2

Note 4: For quality performance, please refer to AUO IIS (Incoming Inspection Standard).

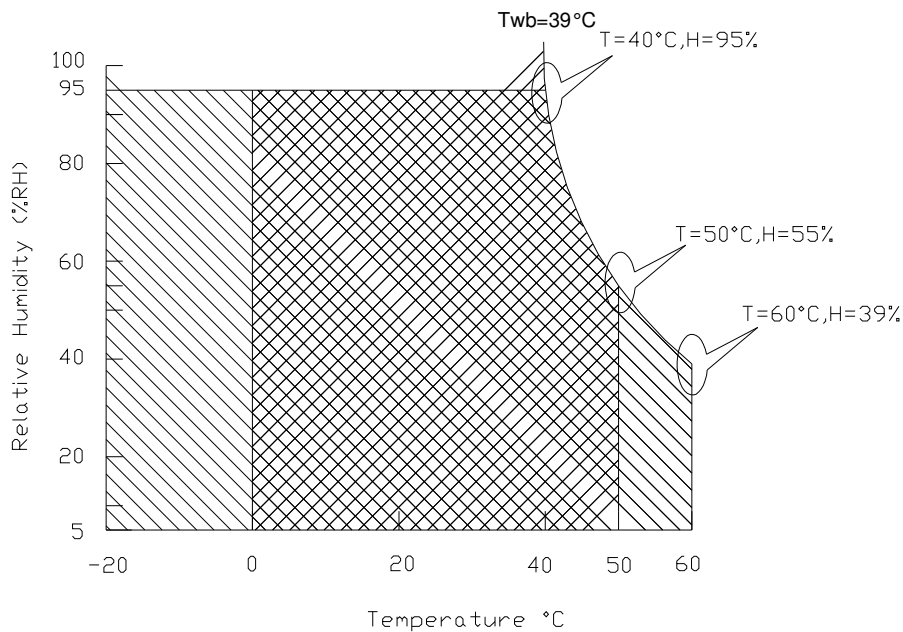

Operating Range 

Storage Range

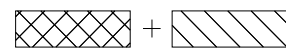

5. Electrical characteristics

5.1 TFT LCD Module

5.1.1 Power Specification

Input power specifications are as follows;

The power specification are measured under 25°C and frame frequency under 60Hz

Symble	Parameter	Min	Typ	Max	Units	Note
VDD	Logic/LCD Drive Voltage	3.0	3.3	3.6	[Volt]	
PDD	VDD Power	-	-	1.6	[Watt]	Note 1/2
IDD	IDD Current	-	350	450	[mA]	Note 1/2
IRush	Inrush Current	-	-	2000	[mA]	Note 3
VDDrp	Allowable Logic/LCD Drive Ripple Voltage	-	-	100	[mV] p-p	

Note 1 : Maximum Measurement Condition : Black Pattern

Note 2 : Typical Measurement Condition: Mosaic Pattern

Note 3 : Measure Condition

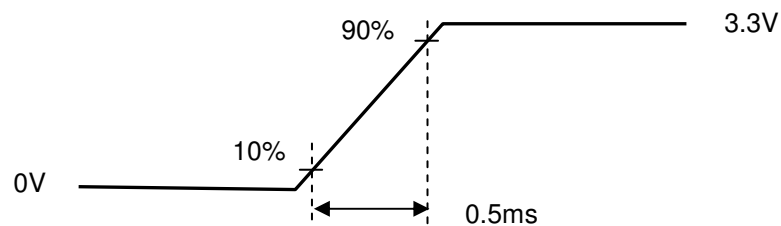
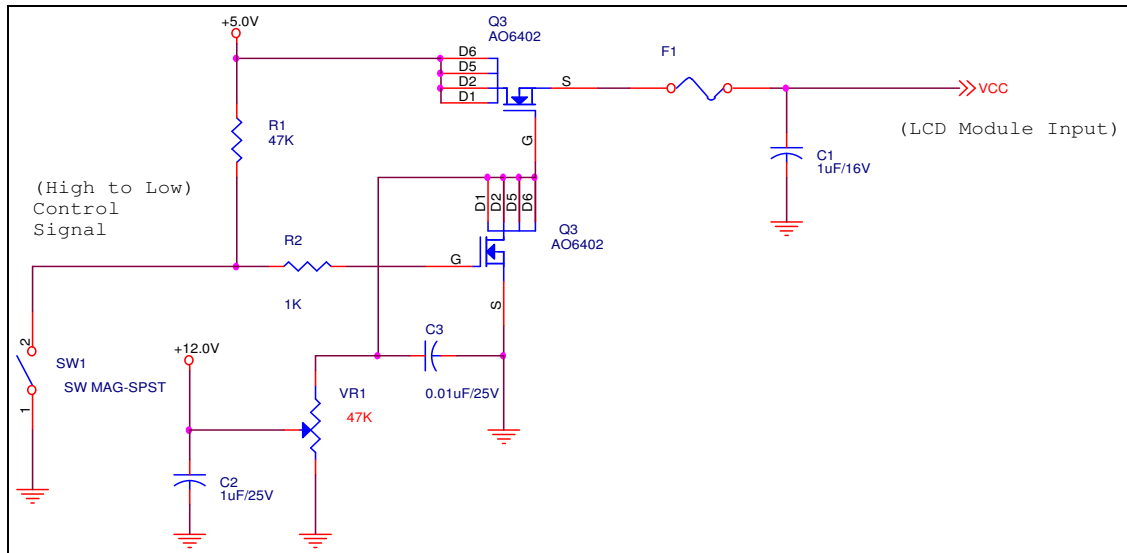

Vin rising time

5.2 Backlight Unit

LED Parameter guideline for LED driving selection (Ref. Remark 1)

Parameter	Symbol	Min	Typ	Max	Units	Condition
LED Forward Voltage	V_F	3.0	3.2	3.4	[Volt]	(Ta=25°C)
LED Forward Current	I_F		20	30	[mA]	(Ta=25°C)
LED Power consumption	P_{LED}		4.35		[Watt]	(Ta=25°C) Note 1
LED Life-Time	N/A	10,000	-	-	Hour	(Ta=25°C) $I_F=20\text{ mA}$ Note 2
Output PWM frequency	F_{PWM}	180	200	220	Hz	
Duty ratio	--	20	--	100	%	

Note 1: Calculator value for reference $I_F \times V_F = P$

Note 2: The LED life-time define as the estimated time to 50% degradation of initial luminous.

6. Signal Characteristic

6.1 Pixel Format Image

Following figure shows the relationship of the input signals and LCD pixel format.

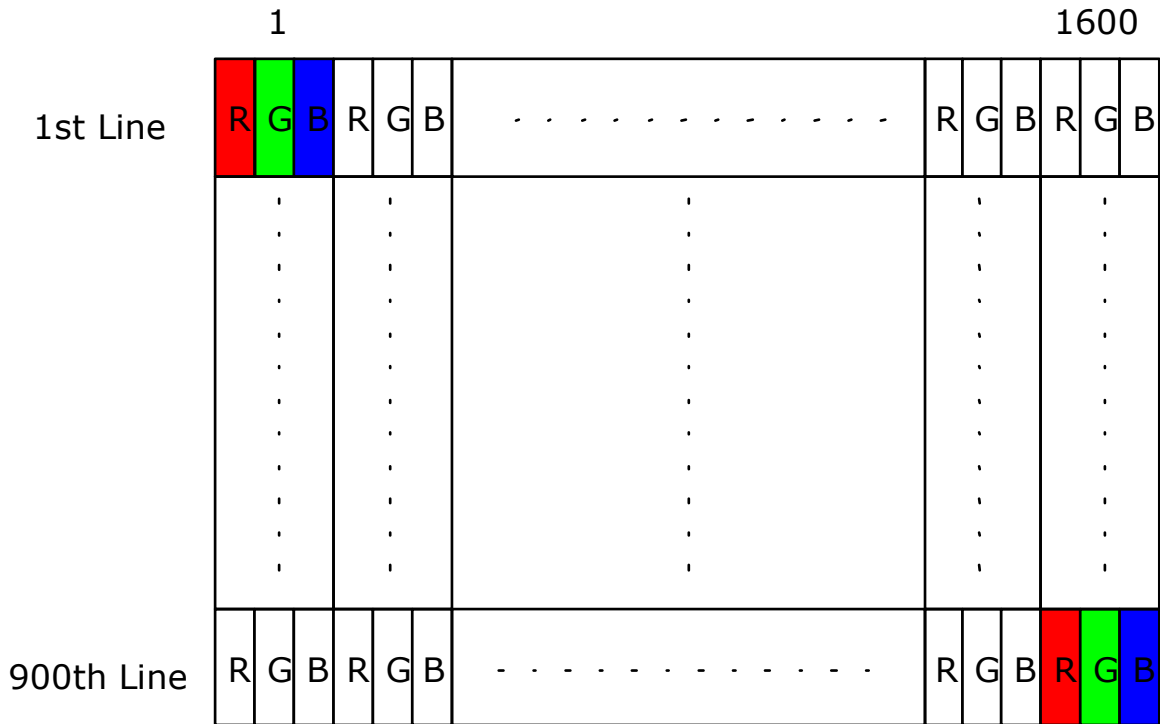

6.2 The input data format

Odd PAIR (1st pixel input)

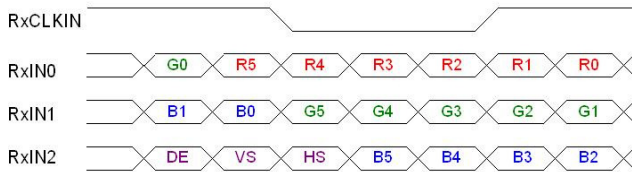

Even PAIR (2nd pixel input)

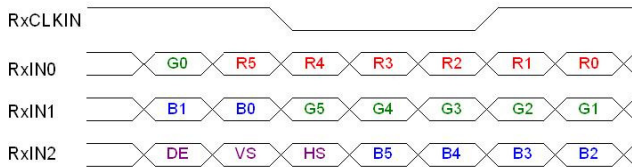

Signal Name	Description	
R5 R4 R3 R2 R1 R0	Red Data 5 (MSB) Red Data 4 Red Data 3 Red Data 2 Red Data 1 Red Data 0 (LSB)	Red-pixel Data Each red pixel's brightness data consists of these 6 bits pixel data.
G5 G4 G3 G2 G1 G0	Green Data 5 (MSB) Green Data 4 Green Data 3 Green Data 2 Green Data 1 Green Data 0 (LSB)	Green-pixel Data Each green pixel's brightness data consists of these 6 bits pixel data.
B5 B4 B3 B2 B1 B0	Blue Data 5 (MSB) Blue Data 4 Blue Data 3 Blue Data 2 Blue Data 1 Blue Data 0 (LSB)	Blue-pixel Data Each blue pixel's brightness data consists of these 6 bits pixel data.
RxCLKIN	Data Clock	The signal is used to strobe the pixel data and DE signals. All pixel data shall be valid at the falling edge when the DE signal is high.
DE	Display Timing	This signal is strobed at the falling edge of RxCLKIN. When the signal is high, the pixel data shall be valid to be displayed.
VS	Vertical Sync	The signal is synchronized to RxCLKIN .
HS	Horizontal Sync	The signal is synchronized to RxCLKIN .

Note: Output signals from any system shall be low or High-impedance state when VDD is off.



6.3 Integration Interface and Pin Assignment

LVDS is a differential signal technology for LCD interface and high speed data transfer device.

PIN#	Signal Name	Description
1	NC	No Connection
2	VDD	Power Supply +3.3V
3	VDD	Power Supply +3.3V
4	VEDID	EDID +3.3V Power
5	NC	No Connect (Reserve for M1 aging)
6	CLKEDID	EDID Clock Input
7	DATAEDID	EDID Data Input
8	RxOIN0-	-LVDS Differential Data INPUT(Odd R0-R5,G0)
9	RxOIN0+	+LVDS Differential Data INPUT(Odd R0-R5,G0)
10	VSS	Ground
11	RxOIN1-	-LVDS Differential Data INPUT(Odd G1-G5,B0-B1)
12	RxOIN1+	+LVDS Differential Data INPUT(Odd G1-G5,B0-B1)
13	VSS	Ground
14	RxOIN2-	-LVDS Differential Data INPUT(Odd B2-B5,HS,VS,DE)
15	RxOIN2+	+LVDS Differential Data INPUT(Odd B2-B5,HS,VS,DE)
16	VSS	Ground
17	RxOCKIN-	-LVDS Odd Differential Clock INPUT
18	RxOCKIN+	+LVDS Odd Differential Clock INPUT
19	VSS	Ground
20	RxEIN0-	-LVDS Differential Data INPUT(Even R0-R5,G0)
21	RxEIN0+	+LVDS Differential Data INPUT(Even R0-R5,G0)
22	VSS	Ground
23	RxEIN1-	-LVDS Differential Data INPUT(Even G1-G5,B0-B1)
24	RxEIN1+	+LVDS Differential Data INPUT(Even G1-G5,B0-B1)
25	VSS	Ground
26	RxEIN2-	-LVDS Differential Data INPUT(Even B2-B5,HS,VS,DE)
27	RxEIN2+	+LVDS Differential Data INPUT(Even B2-B5,HS,VS,DE)
28	VSS	Ground
29	RxECKIN-	-LVDS Even Differential Clock INPUT
30	RxECKIN+	+LVDS Even Differential Clock INPUT
31	VLED_GND	LED Ground
32	VLED_GND	LED Ground
33	VLED_GND	LED Ground
34	NC	No Connection



Product Specification

AU OPTRONICS CORPORATION

35	S_PWMIN	System PWM signal Input
36	LED_EN	LED Enable Pin(+3V Input)
37	NC	No Connection
38	VLED	LED Power Supply 7V-21V
39	VLED	LED Power Supply 7V-21V
40	VLED	LED Power Supply 7V-21V

Note1: Start from right side

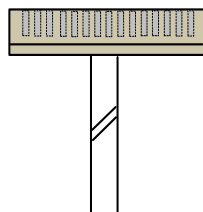
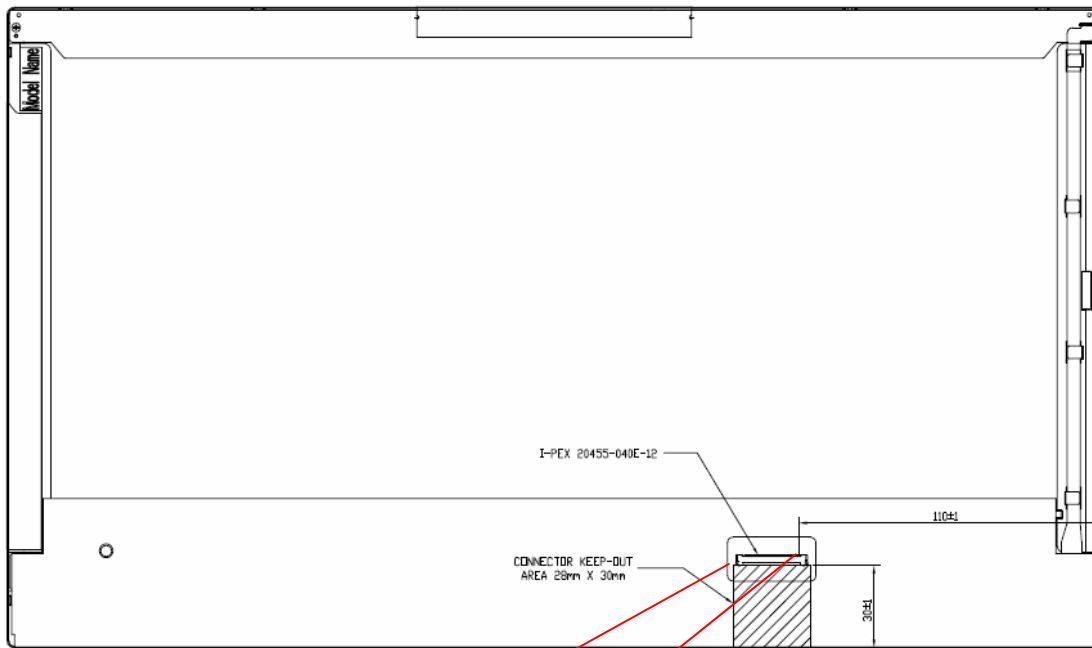

Note2: Input signals shall be low or High-impedance state when VDD is off.

internal circuit of LVDS inputs are as following.

The module uses a 100ohm resistor between positive and negative data lines of each receiver input

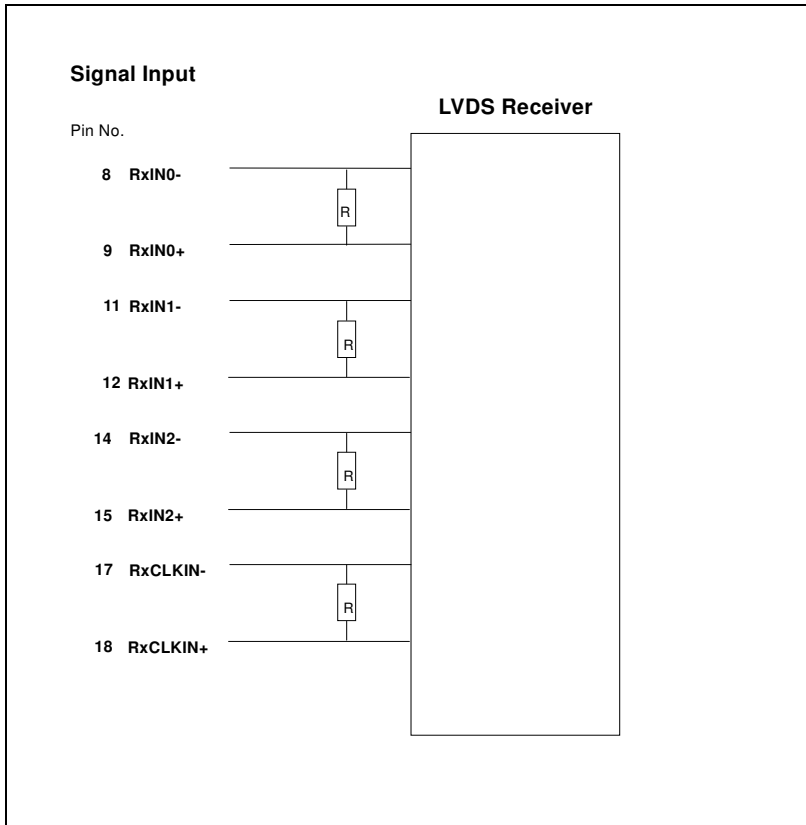

6.4 Interface Timing

6.4.1 Timing Characteristics

Basically, interface timings should match the 1600x900 /60Hz manufacturing guide line timing.

Parameter	Symbol	Min.	Typ.	Max.	Unit
Frame Rate	-		60	-	Hz
Clock frequency	$1/T_{Clock}$		52.8		MHz
Vertical Section	Period	T_V	912		T_{Line}
	Active	T_{VD}	900		
	Blanking	T_{VB}	12		
Horizontal Section	Period	T_H	1930		T_{Clock}
	Active	T_{HD}	1600		
	Blanking	T_{HB}	330		

Note : DE mode only

6.4.2 Timing diagram

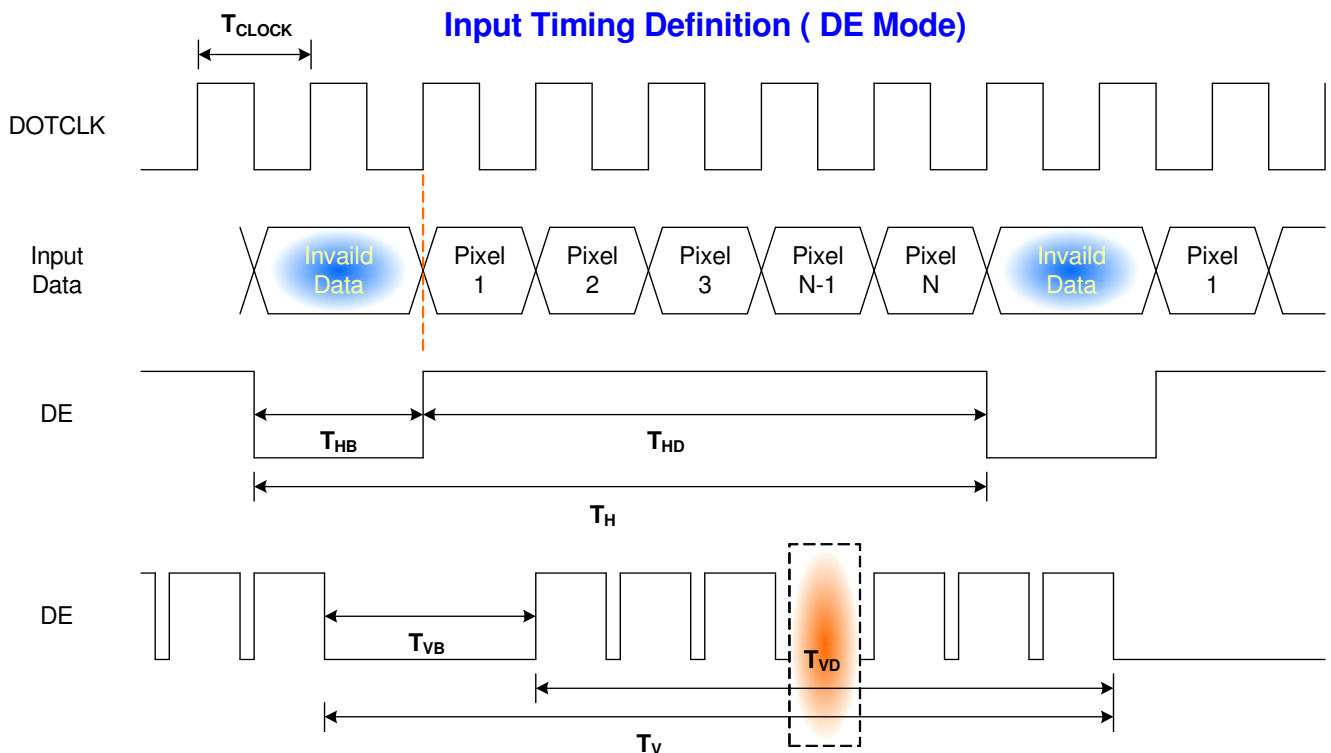

6.5 Power ON/OFF Sequence

VDD power on/off sequence is as follows. Interface signals are also shown in the chart. Signals from any system shall be Hi-Z state or low level when VDD is off

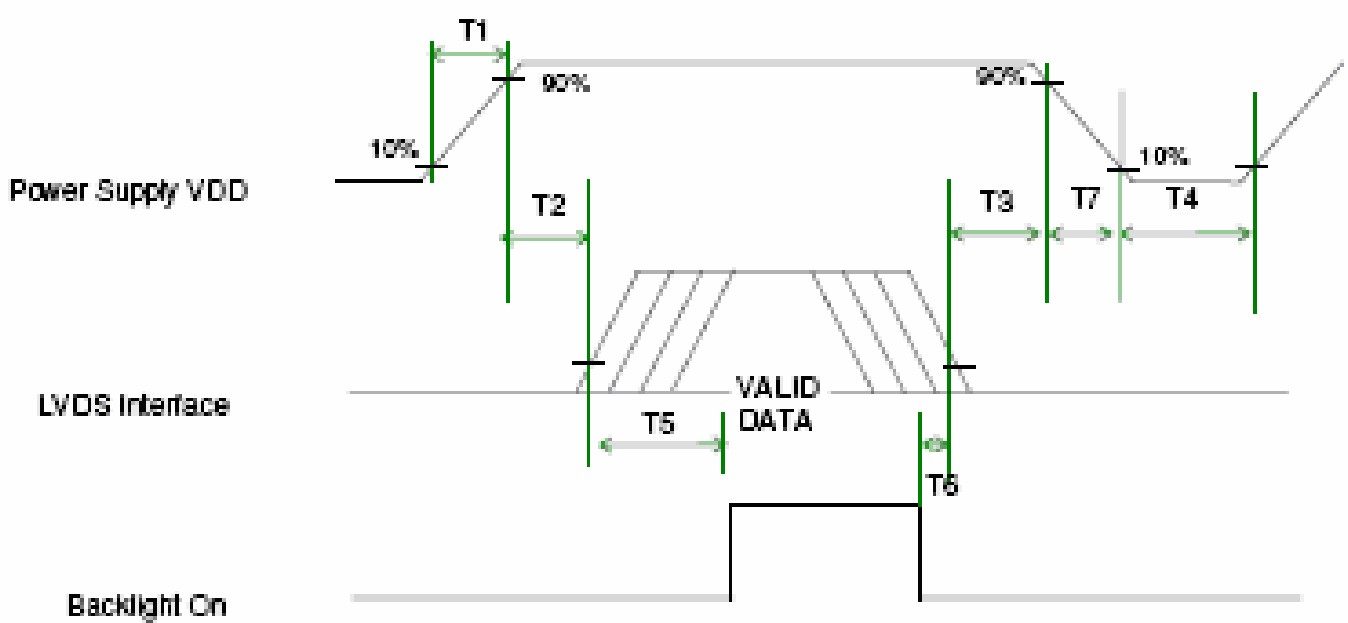

Power Sequence Timing

Parameter	Value			Units
	Min.	Typ.	Max.	
T1	0.5	-	10	ms
T2	0	-	50	
T3	0	-	50	
T4	400	-	-	
T5	200	-	-	
T6	200	-	-	
T7	0	-	10	

LED on/off sequence is as follows. Interface signals are also shown in the chart.

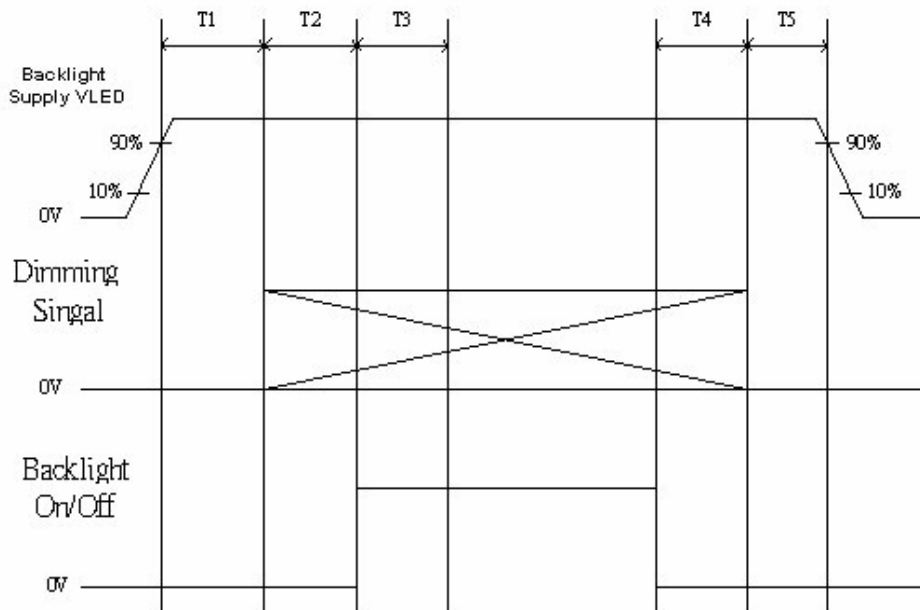

Symbol	Values			Unit
	Min	Typ	Max	
T1	10	---	---	ms
T2	10	---	---	
T3	50	---	---	
T4	0	---	---	
T5	10	---	---	

Note: The duty of LED dimming signal should be more than 20% in T2 and T3.

7. Connector Description

Physical interface is described as for the connector on module.

These connectors are capable of accommodating the following signals and will be following components.

7.1 TFT LCD Module

Connector Name / Designation	For Signal Connector
Manufacturer	IPEX
Type / Part Number	IPEX 20455-040E-12
Mating Housing/Part Number	Starconn 089N14-000R00-G2-R



8. LED Driving Specification

8.1 Connector Description

It is a integrative interface and comibe into LVDS connector. The type and mating refer to section 7.

8.2 Pin Assignment

Ref. to 6.3



9. Vibration and Shock Test

9.1 Vibration Test

Test Spec:

- Test method: Non-Operation
- Acceleration: 1.5 G
- Frequency: 10 - 500Hz Random
- Sweep: 30 Minutes each Axis (X, Y, Z)

9.2 Shock Test Spec:

Test Spec:

- Test method: Non-Operation
- Acceleration: TBD G , Half sine wave
- Active time: 2 ms
- Pulse: X,Y,Z .one time for each side



10. Reliability

Items	Required Condition	Note
Temperature Humidity Bias	Ta= 40°C, 90%RH, 300h	
High Temperature Operation	Ta= 50°C, Dry, 300h	
Low Temperature Operation	Ta= 0°C, 300h	
High Temperature Storage	Ta= 60°C, 35%RH, 300h	
Low Temperature Storage	Ta= -20°C, 50%RH, 250h	
Thermal Shock Test	Ta=-20°C to 60°C, Duration at 30 min, 100 cycles	
ESD	Contact : ±8 KV Air : ±15 KV	Note 1

Note1: According to EN 61000-4-2 , ESD class B: Some performance degradation allowed. No data lost
. Self-recoverable. No hardware failures.

Remark: MTBF (Excluding the LED): 30,000 hours with a confidence level 90%



Product Specification

AU OPTRONICS CORPORATION

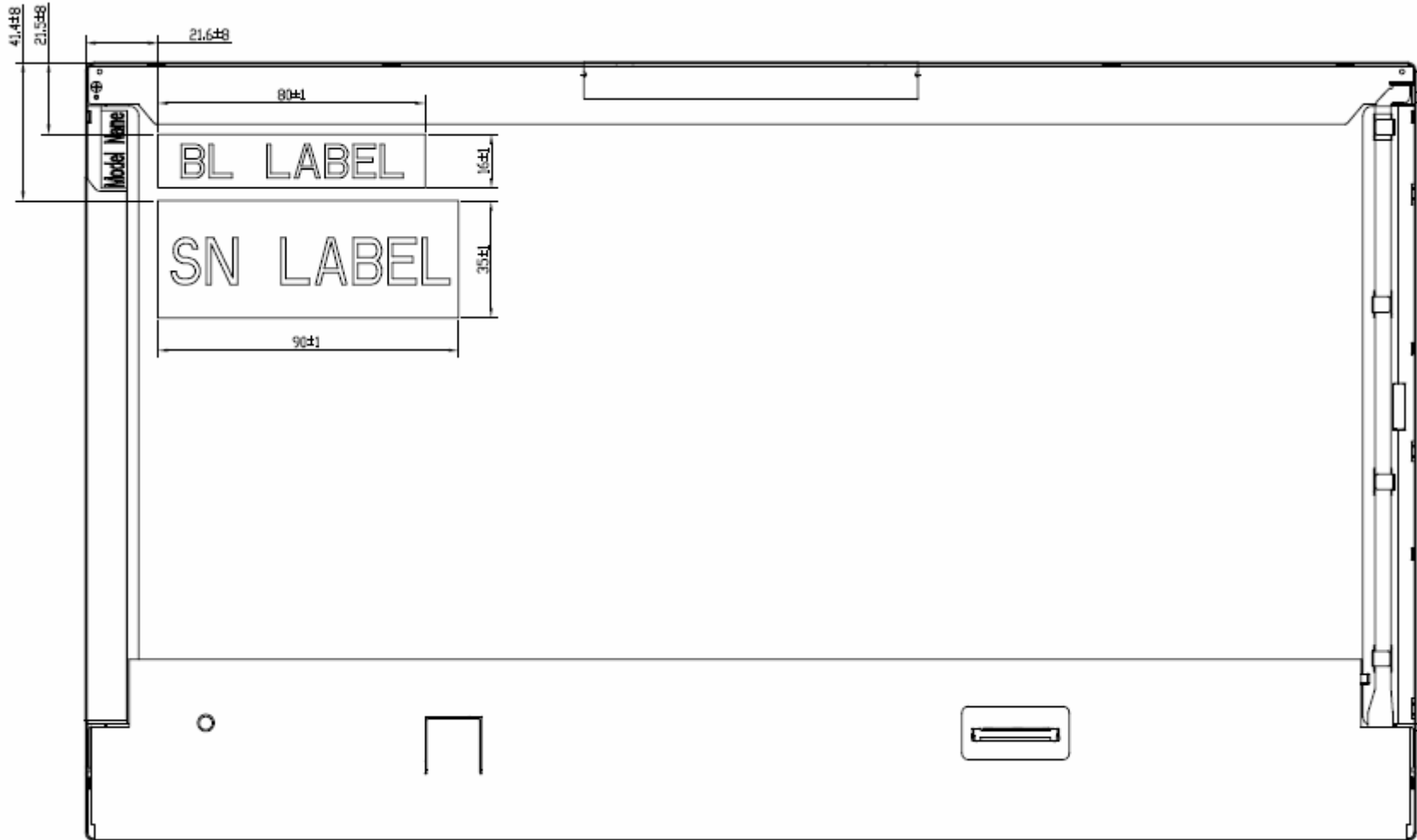

11.2 Screw Hole Depth and Center Position

Screw hole minimum depth, from side surface = 2.5 mm (See drawing)

Screw hole center location, from front surface = 3.1 ± 0.3 mm (See drawing)

Screw Torque: Maximum 2.5 kgf-cm

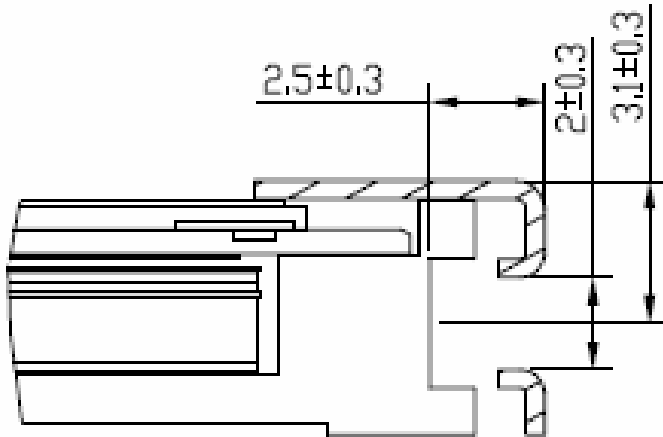



12. Shipping and Package

12.1 Shipping Label Format

12.2 Carton package

The outside dimension of carton is 480 (L)mm x 373 (W)mm x 311 (H)mm

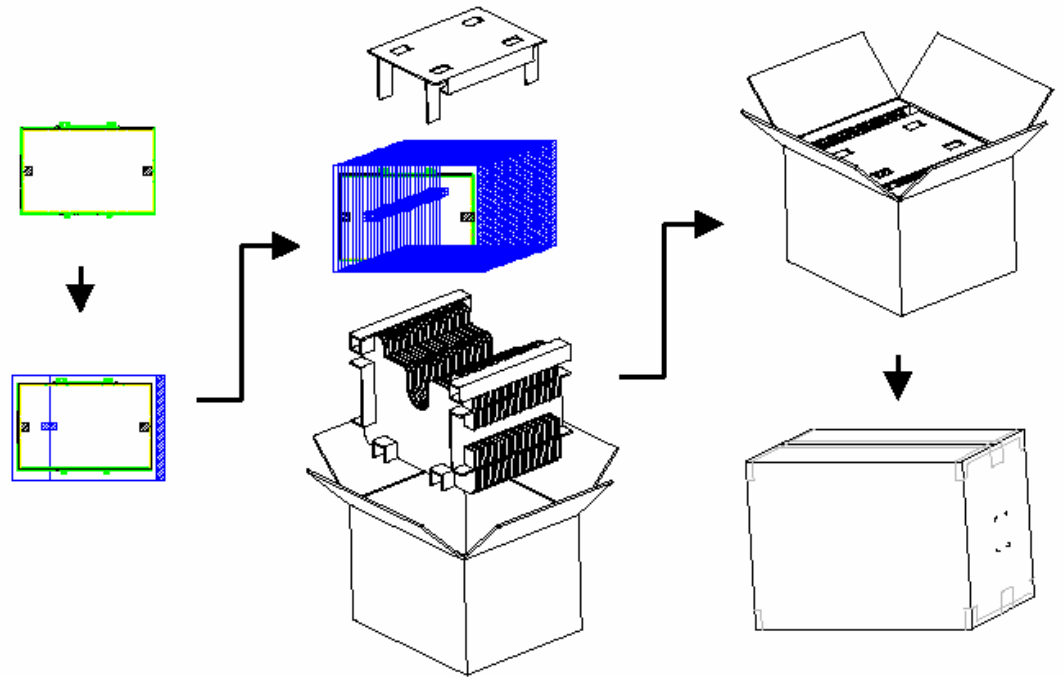

12.3 Shipping package of palletizing sequence

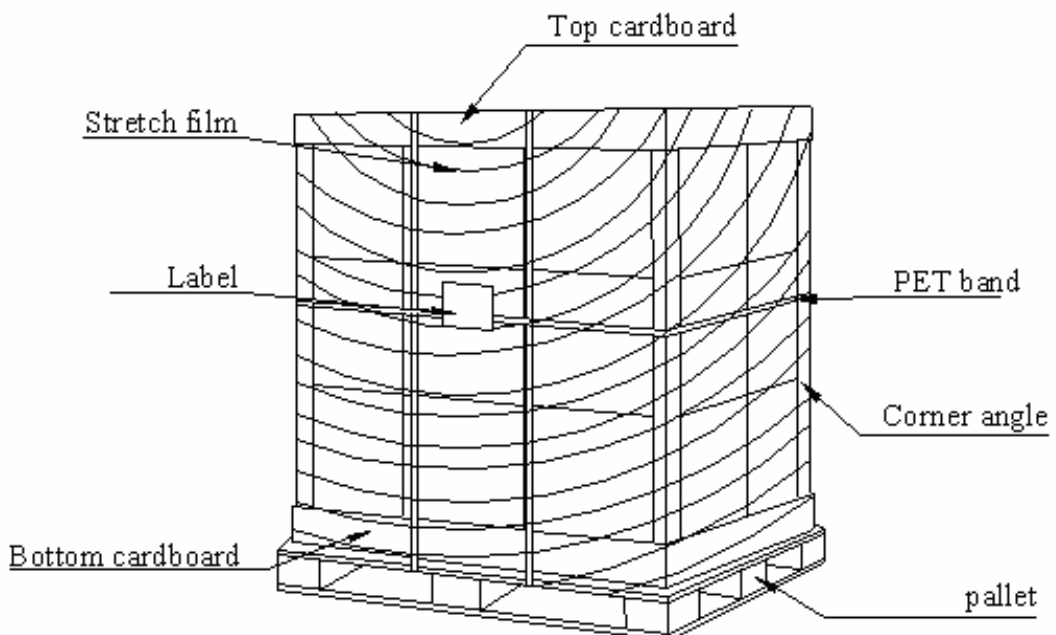



Product Specification

AU OPTRONICS CORPORATION

13. Appendix: EDID description

Address	FUNCTION	Value	Value	Value	Note
00	Header	00	00000000	0	
01		FF	11111111	255	
02		FF	11111111	255	
03		FF	11111111	255	
04		FF	11111111	255	
05		FF	11111111	255	
06		FF	11111111	255	
07		00	00000000	0	
08	EISA Manuf. Code LSB	06	00000110	6	
09	Compressed ASCII	AF	10101111	175	
0A	Product Code	9E	10011110	158	
0B	hex, LSB first	11	00010001	17	
0C	32-bit ser #	00	00000000	0	
0D		00	00000000	0	
0E		00	00000000	0	
0F		00	00000000	0	
10	Week of manufacture	01	00000001	1	
11	Year of manufacture	12	00010010	18	
12	EDID Structure Ver.	01	00000001	1	
13	EDID revision #	03	00000011	3	
14	Video input def. (<i>digital I/P, non-TMDS, CRGB</i>)	80	10000000	128	
15	Max H image size (<i>rounded to cm</i>)	26	00100110	38	
16	Max V image size (<i>rounded to cm</i>)	15	00010101	21	
17	Display Gamma (<i>=(gamma*100)-100</i>)	78	01111000	120	
18	Feature support (<i>no DPMS, Active OFF, RGB, tmg Blk#1</i>)	0A	00001010	10	
19	Red/green low bits (Lower 2:2:2:2 bits)	45	01000101	69	
1A	Blue/white low bits (Lower 2:2:2:2 bits)	25	00100101	37	
1B	Red x (Upper 8 bits)	9C	10011100	156	
1C	Red y/ highER 8 bits	5B	01011011	91	
1D	Green x	55	01010101	85	
1E	Green y	9C	10011100	156	
1F	Blue x	27	00100111	39	
20	Blue y	19	00011001	25	
21	White x	50	01010000	80	
22	White y	54	01010100	84	
23	Established timing 1	00	00000000	0	



Product Specification

AU OPTRONICS CORPORATION

24	Established timing 2	00	00000000	0	
25	Established timing 3	00	00000000	0	
26	Standard timing #1	01	00000001	1	
27		01	00000001	1	
28	Standard timing #2	01	00000001	1	
29		01	00000001	1	
2A	Standard timing #3	01	00000001	1	
2B		01	00000001	1	
2C	Standard timing #4	01	00000001	1	
2D		01	00000001	1	
2E	Standard timing #5	01	00000001	1	
2F		01	00000001	1	
30	Standard timing #6	01	00000001	1	
31		01	00000001	1	
32	Standard timing #7	01	00000001	1	
33		01	00000001	1	
34	Standard timing #8	01	00000001	1	
35		01	00000001	1	
36	Pixel Clock/10000 LSB	40	01000000	64	
37	Pixel Clock/10000 USB	29	00101001	41	
38	Horz active Lower 8bits	40	01000000	64	
39	Horz blanking Lower 8bits	4A	01001010	74	
3A	HorzAct:HorzBlnk Upper 4:4 bits	61	01100001	97	
3B	Vertical Active Lower 8bits	84	10000100	132	
3C	Vertical Blanking Lower 8bits	0C	00001100	12	
3D	Vert Act : Vertical Blanking (upper 4:4 bit)	30	00110000	48	
3E	HorzSync. Offset	40	01000000	64	
3F	HorzSync.Width	2A	00101010	42	
40	VertSync.Offset : VertSync.Width	33	00110011	51	
41	Horz&Vert Sync Offset/Width Upper 2bits	00	00000000	0	
42	Horizontal Image Size Lower 8bits	7E	01111110	126	
43	Vertical Image Size Lower 8bits	D6	11010110	214	
44	Horizontal & Vertical Image Size (upper 4:4 bits)	10	00010000	16	
45	Horizontal Border <i>(zero for internal LCD)</i>	00	00000000	0	
46	Vertical Border <i>(zero for internal LCD)</i>	00	00000000	0	
47	Signal <i>(non-intr, norm, no stero, sep sync, neg pol)</i>	18	00011000	24	
48	Detailed timing/monitor	00	00000000	0	
49	descriptor #2	00	00000000	0	
4A		00	00000000	0	



Product Specification

AU OPTRONICS CORPORATION

4B		0F	00001111	15	
4C		00	00000000	0	
4D		00	00000000	0	
4E		00	00000000	0	
4F		00	00000000	0	
50		00	00000000	0	
51		00	00000000	0	
52		00	00000000	0	
53		00	00000000	0	
54		00	00000000	0	
55		00	00000000	0	
56		00	00000000	0	
57		00	00000000	0	
58		00	00000000	0	
59		20	00100000	32	
5A	Detailed timing/monitor	00	00000000	0	
5B	descriptor #3	00	00000000	0	
5C		00	00000000	0	
5D		FE	11111110	254	
5E		00	00000000	0	
5F	Manufacture	41	01000001	65	A
60	Manufacture	55	01010101	85	U
61	Manufacture	4F	01001111	79	O
62		0A	00001010	10	
63		20	00100000	32	
64		20	00100000	32	
65		20	00100000	32	
66		20	00100000	32	
67		20	00100000	32	
68		20	00100000	32	
69		20	00100000	32	
6A		20	00100000	32	
6B		20	00100000	32	
6C	Detailed timing/monitor	00	00000000	0	
6D	descriptor #4	00	00000000	0	
6E		00	00000000	0	
6F		FE	11111110	254	
70		00	00000000	0	
71	Manufacture P/N	42	01000010	66	B



Product Specification

AU OPTRONICS CORPORATION

72	Manufacture P/N	31	00110001	49	1
73	Manufacture P/N	37	00110111	55	7
74	Manufacture P/N	33	00110011	51	3
75	Manufacture P/N	52	01010010	82	R
76	Manufacture P/N	57	01010111	87	W
77	Manufacture P/N	30	00110000	48	0
78	Manufacture P/N	31	00110001	49	1
79	Manufacture P/N	20	00100000	32	
7A	Manufacture P/N	56	01010110	86	V
7B	Manufacture P/N	31	00110001	49	1
7C		20	00100000	32	
7D		0A	00001010	10	
7E	Extension Flag	00	00000000	0	
7F	Checksum	E9	11101001	233	