



# AU OPTRONICS CORPORATION

## Product Specification

### 15.4" WXGA Color TFT-LCD Module

**Model Name: B154EW01 VC Rev A00**  
**Dell P/N: FF059**  
**Inverter: Foxconn + Maximum 6.0**

Approved by	Prepared by
<i>Joselyn Liu</i>	<i>Jerry Chen</i>

*MDBU Marketing Division / AU Optronics corporation*

Customer	Checked & Approved by



## Product Specification

### 15.4" WXGA Color TFT-LCD Module

Model Name: B154EW01

V.C Rev A00

Dell P/N : FF059

Inverter: Foxconn + Maximum 6.0

( ) Preliminary Specifications

(V ) Final Specifications

**Note: This Specification is subject to change without notice.**



## Contents

<b>1. Handling Precautions .....</b>	<b>5</b>
<b>2. General Description .....</b>	<b>5</b>
2.1 Display Characteristics .....	6
2.2 Optical Characteristics.....	7
<b>3. Functional Block Diagram.....</b>	<b>12</b>
<b>4. Absolute Maximum Ratings .....</b>	<b>13</b>
4.1 TFT LCD Module .....	13
4.2 Backlight Unit.....	13
4.3 Absolute Ratings of Environment.....	13
<b>5. Electrical characteristics.....</b>	<b>14</b>
5.1 TFT LCD Module .....	14
5.2 Backlight Unit.....	16
<b>6. Signal Characteristic .....</b>	<b>19</b>
6.1 Pixel Format Image.....	19
6.2 The input data format.....	20
6.3 Signal Description.....	21
6.4 Interface Timing .....	23
6.5 Power ON/OFF Sequence .....	25
<b>7. Connector &amp; Pin Assignment .....</b>	<b>26</b>
7.1 TFT LCD Module .....	26
7.2 Backlight Unit.....	26
7.3 Signal for Lamp connector.....	26
<b>8. Vibration and Shock Test.....</b>	<b>27</b>
8.1 Vibration Test.....	27
8.2 Shock Test Spec: .....	27
<b>9. Reliability .....</b>	<b>28</b>
<b>10. Mechanical Characteristics.....</b>	<b>29</b>
10.1 LCM Outline Dimension.....	29
10.2 Screw Hole Depth and Center Position .....	30
<b>11. Shipping and Package.....</b>	<b>31</b>
11.1 Shipping Label Format.....	31
11.2. Carton package.....	32
11.3 Shipping package of palletizing sequence .....	32
<b>12. Appendix: EDID description.....</b>	<b>33</b>



## Record of Revision

Version and Date	Page	Old description	New Description	Remark
0.1 2005/08/01	All	First Edition for Customer		
0.2 2005/08/15	18		Update Inverter Characteristic Spec.	
0.3 2006/01/09	33		Update EDID description	



## 1. Handling Precautions

- 1) Since front polarizer is easily damaged, pay attention not to scratch it.
- 2) Be sure to turn off power supply when inserting or disconnecting from input connector.
- 3) Wipe off water drop immediately. Long contact with water may cause discoloration or spots.
- 4) When the panel surface is soiled, wipe it with absorbent cotton or other soft cloth.
- 5) Since the panel is made of glass, it may break or crack if dropped or bumped on hard surface.
- 6) Since CMOS LSI is used in this module, take care of static electricity and insure human earth when handling.
- 7) Do not open nor modify the Module Assembly.
- 8) Do not press the reflector sheet at the back of the module to any directions.
- 9) In case if a Module has to be put back into the packing container slot after once it was taken out from the container, do not press the center of the CCFL Reflector edge. Instead, press at the far ends of the CFL Reflector edge softly. Otherwise the TFT Module may be damaged.
- 10) At the insertion or removal of the Signal Interface Connector, be sure not to rotate nor tilt the Interface Connector of the TFT Module.
- 11) After installation of the TFT Module into an enclosure (Notebook PC Bezel, for example), do not twist nor bend the TFT Module even momentary. At designing the enclosure, it should be taken into consideration that no bending/twisting forces are applied to the TFT Module from outside. Otherwise the TFT Module may be damaged.
- 12) Cold cathode fluorescent lamp in LCD contains a small amount of mercury. Please follow local ordinances or regulations for disposal.
- 13) Small amount of materials having no flammability grade is used in the LCD module. The LCD module should be supplied by power complied with requirements of Limited Power Source(, IEC60950 or UL1950), or be applied exemption.
- 14) The LCD module is designed so that the CCFL in it is supplied by Limited Current Circuit(IEC60950 or UL1950). Do not connect the CCFL in Hazardous Voltage Circuit.

## 2. General Description

B154EW01 V8 is a Color Active Matrix Liquid Crystal Display composed of a TFT LCD panel, a driver circuit, and backlight system. The screen format is intended to support the WXGA (1280(H) x 800(V)) screen and 262k colors (RGB 6-bits data driver). All input signals are LVDS interface compatible. Inverter of backlight is not included.



B154EW01 VC is designed for a display unit of notebook style personal computer and industrial machine.

## 2.1 General Specification

The following items are characteristics summary on the table at 25 condition:

Items	Unit	Specifications
Screen Diagonal	[mm]	391 (15.4W")
Active Area	[mm]	331.2 X 207.0
Pixels H x V		1280x3(RGB) x 800
Pixel Pitch	[mm]	0.2588X0.2588
Pixel Arrangement		R.G.B. Vertical Stripe
Display Mode		Normally White
White Luminance (I <sub>CCFL</sub> =6.0mA) Note: I <sub>CCFL</sub> is lamp current	[cd/m <sup>2</sup> ]	160 typ. (5 points average) 150 min. (5 points average) (Note1)
Luminance Uniformity		1.25 max. (5 points)
Contrast Ratio		400 typ
Optical Rise Time/Fall Time	[msec]	4/12 typ.
Nominal Input Voltage VDD	[Volt]	+3.3 typ.
Power Consumption	[Watt]	6.5 max.(without inverter)
Weight(w/o Inverter)	[Grams]	585 max.
Physical Size	[mm]	344.0 typ. x 222.0 typ. x 6.5 max.
Electrical Interface		1 channel LVDS
Surface Treatment		Glare, Hardness 3H, ,Reflectance 4.3%
Support Color		262K colors ( RGB 6-bit )
Temperature Range Operating Storage (Non-Operating)	[°C] [°C]	0 to +50 -20 to +60
RoHS Compliance		RoHS Compliance



## 2.2 Optical Characteristics

The optical characteristics are measured under stable conditions at 25 (Room Temperature):

Item	Unit	Conditions	Min.	Typ.	Max.	Note
White Luminance I <sub>CCFL</sub> =6.0mA	[cd/m <sup>2</sup> ]	5 points average	150	160	-	1, 4, 5.
Viewing Angle	[degree]	Horizontal (Right)	-	40	-	9
	[degree]	CR = 10 (Left)	-	40	-	
	[degree]	Vertical (Upper)	-	10	-	
	[degree]	CR = 10 (Lower)	-	30	-	
Luminance Uniformity		5 Points			1.25	1
Luminance Uniformity		13 Points			1.50	2
CR: Contrast Ratio			300	400	-	6
Cross talk	%				4	7
Response Time	[msec]	Rising	-	4	8	8
	[msec]	Falling	-	12	17	
	[msec]	Rising + Falling		16	25	
Color / Chromaticity Coordinates (CIE 1931)		Red x	0.570	0.600	0.630	2,8
		Red y	0.300	0.340	0.370	
		Green x	0.280	0.310	0.340	
		Green y	0.530	0.560	0.590	
		Blue x	0.120	0.150	0.180	
		Blue y	0.085	0.115	0.145	
		White x	0.290	0.313	0.343	
		White y	0.299	0.329	0.350	

Note 1: 5 points position (Display area : 331.2mm x 207.0mm)

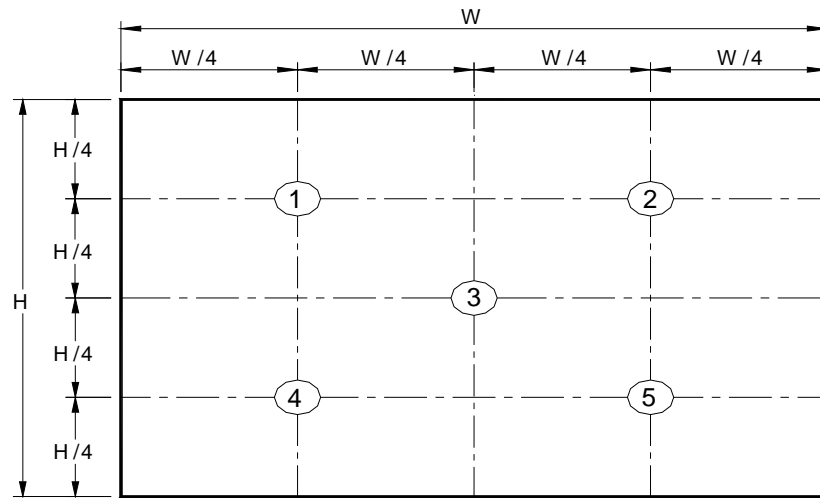

Note 2: 13 points position

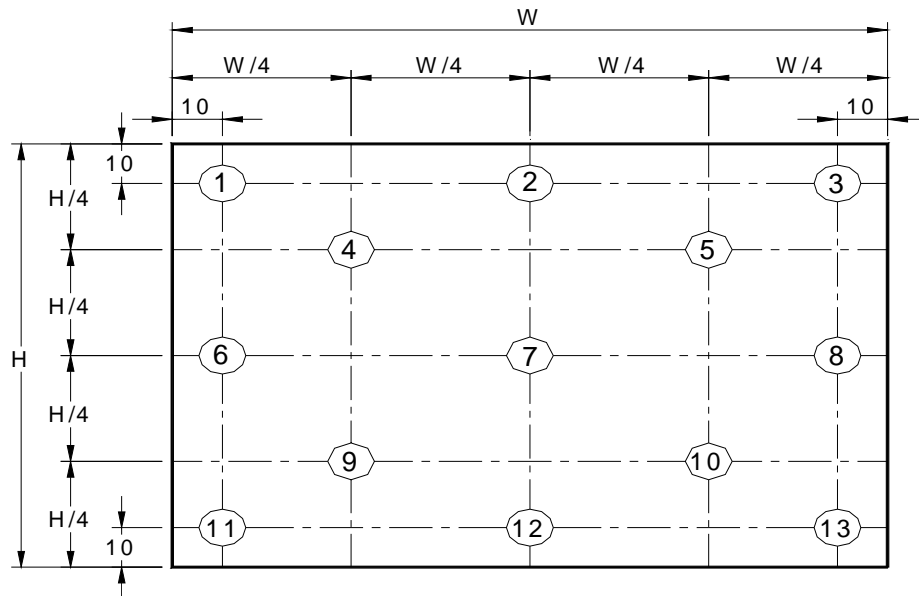

Note 3: The luminance uniformity of 5 and 13 points is defined by dividing the maximum luminance values by the minimum test point luminance

$$w_5 = \frac{\text{Maximum Brightness of five points}}{\text{Minimum Brightness of five points}}$$

$$w_{13} = \frac{\text{Maximum Brightness of thirteen points}}{\text{Minimum Brightness of thirteen points}}$$

#### Note 4: Measurement method

The LCD module should be stabilized at given temperature for 30 minutes to avoid abrupt temperature change during measuring. In order to stabilize the luminance, the measurement should be executed after lighting Backlight for 30 minutes in a stable, windless and dark room.

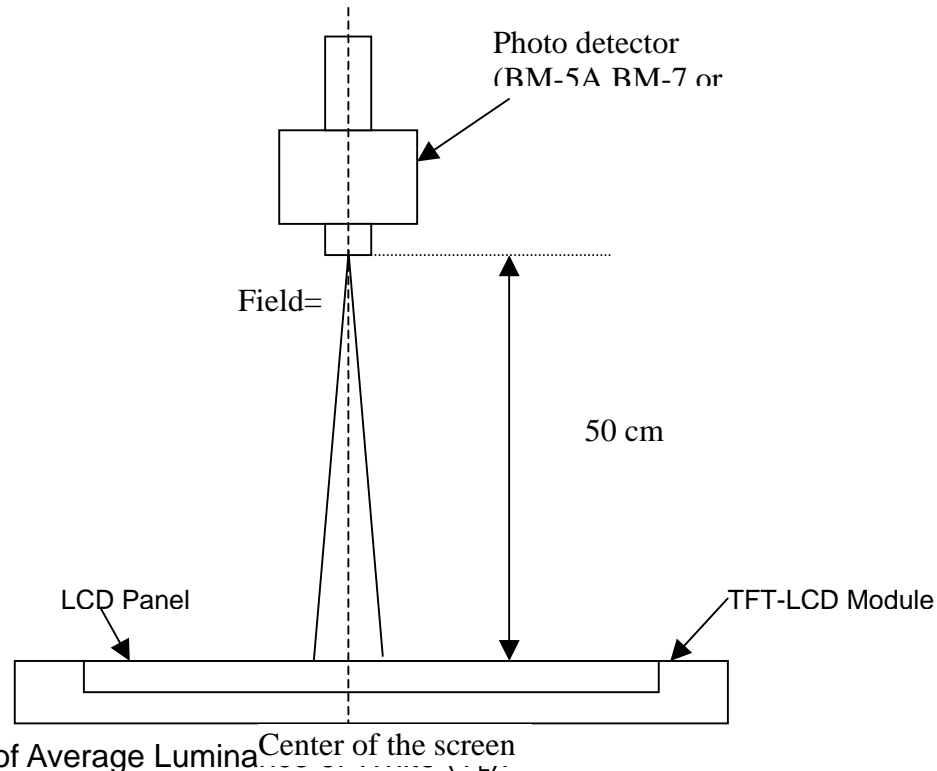

#### Note 5 : Definition of Average Luminance

Measure the luminance of gray level 63 at 5 points ,  $Y_L = [L(1) + L(2) + L(3) + L(4) + L(5)] / 5$   
 $L(x)$  is corresponding to the luminance of the point X at Figure in Note (1).

#### Note 6 : Definition of contrast ratio:

Contrast ratio is calculated with the following formula.

$$\text{Contrast ratio (CR)} = \frac{\text{Brightness on the "White" state}}{\text{Brightness on the "Black" state}}$$

#### Note 7 : Definition of Cross Talk (CT)

$$CT = |Y_B - Y_A| / Y_A \times 100 (\%)$$

Where

$Y_A$  = Luminance of measured location without gray level 0 pattern (cd/m<sup>2</sup>)

$Y_B$  = Luminance of measured location with gray level 0 pattern (cd/m<sup>2</sup>)



Product Specification



Note 8: Definition of response time:

The output signals of BM-7 or equivalent are measured when the input signals are changed from "Black" to "White" (falling time) and from "White" to "Black" (rising time), respectively. The response time interval between the 10% and 90% of amplitudes. Refer to figure as below.

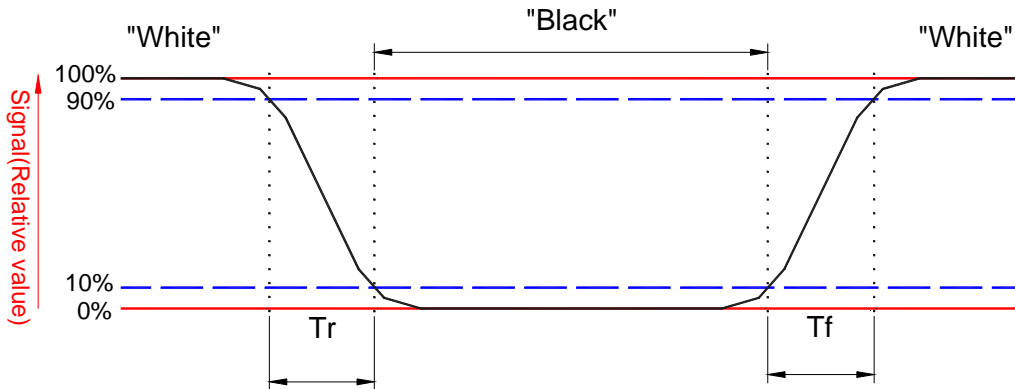



Note 9. Definition of viewing angle

Viewing angle is the measurement of contrast ratio  $\geq 10$ , at the screen center, over a  $180^\circ$  horizontal and  $180^\circ$  vertical range (off-normal viewing angles). The  $180^\circ$  viewing angle range is broken down as follows;  $90^\circ$  ( ) horizontal left and right and  $90^\circ$  ( ) vertical, high (up) and low (down). The measurement direction is typically perpendicular to the display surface with the screen rotated about its center to develop the desired measurement viewing angle.

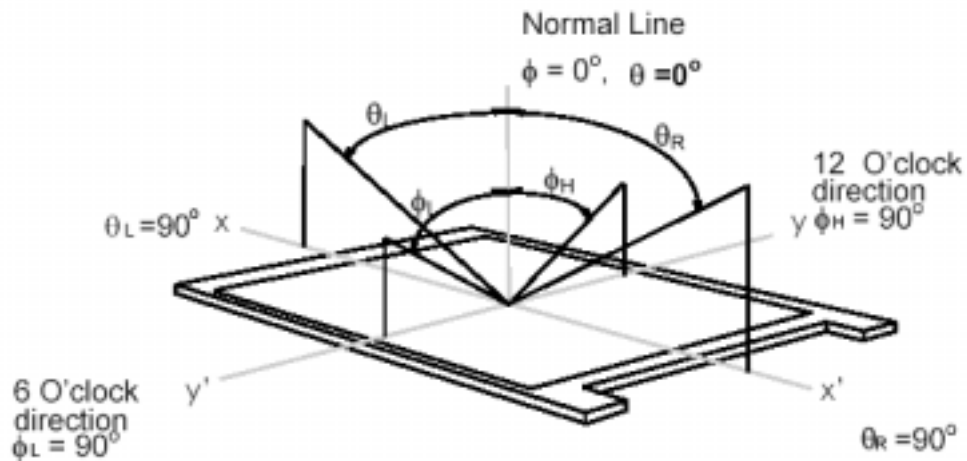



### 3. Functional Block Diagram

The following diagram shows the functional block of the 15.4 inches wide Color TFT/LCD Module:

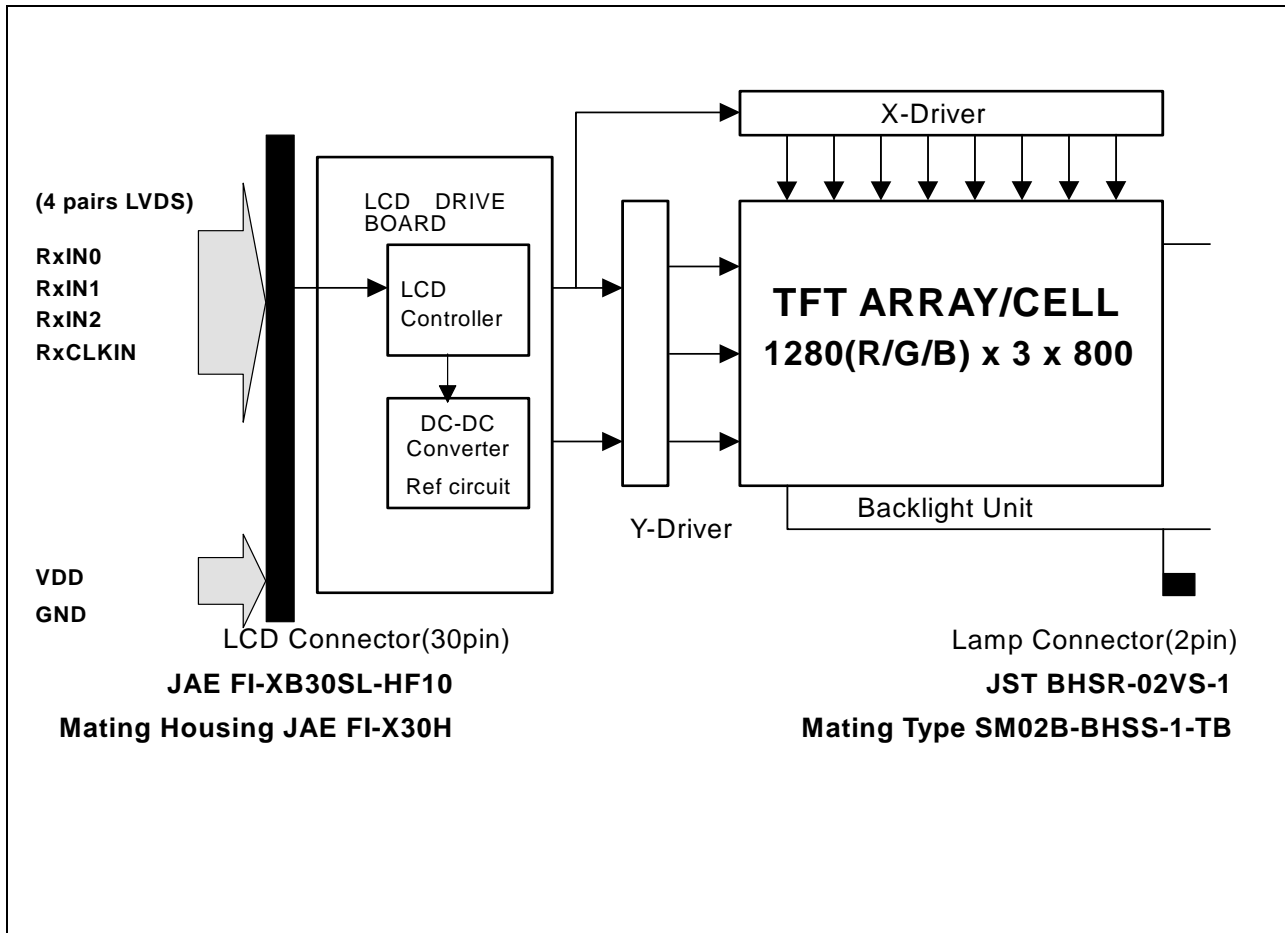



### 4. Absolute Maximum Ratings

Absolute maximum ratings of the module is as following:

#### 4.1 Absolute Ratings of TFT LCD Module

Item	Symbol	Min	Max	Unit	Conditions
Logic/LCD Drive Voltage	Vin	-0.3	+4.0	[Volt]	Note 1,2

#### 4.2 Absolute Ratings of Backlight Unit

Item	Symbol	Min	Max	Unit	Conditions
CCFL Current	ICCFL	-	6.5	[mA] rms	Note 1,2

#### 4.3 Absolute Ratings of Environment

Item	Symbol	Min	Max	Unit	Conditions
Operating Temperature	TOP	0	+50	[°C]	Note 3
Operation Humidity	HOP	5	95	[%RH]	Note 3
Storage Temperature	TST	-20	+60	[°C]	Note 3
Storage Humidity	HST	5	95	[%RH]	Note 3

Note 1: At Ta (25 )

Note 2: Permanent damage to the device may occur if exceed maximum values

Note 3: For quality performance, please refer to AUO IIS(Incoming Inspection Standard).

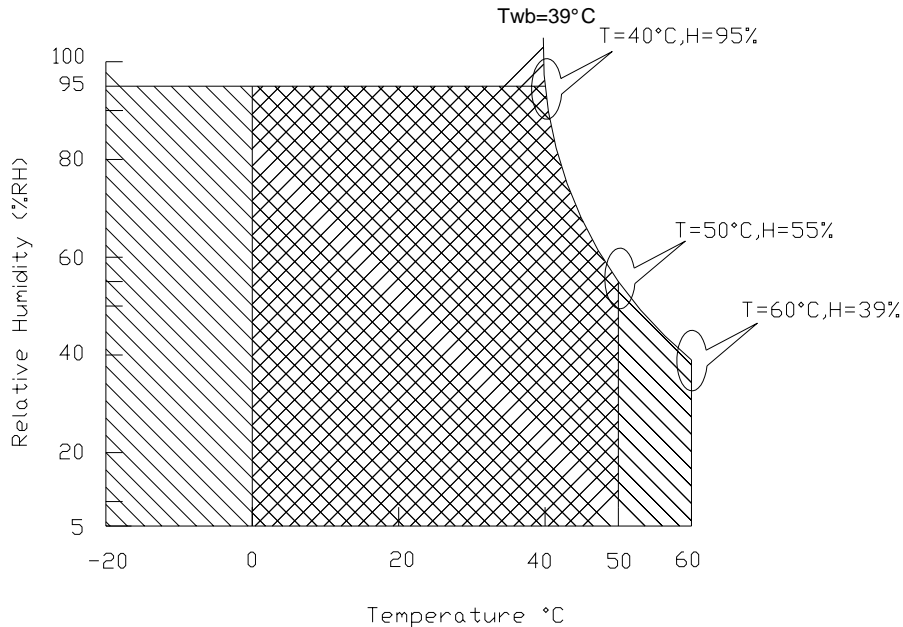

Operating Range



Storage Range

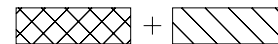



## 5. Electrical characteristics

### 5.1 TFT LCD Module

#### 5.1.1 Power Specification

Input power specifications are as follows;

Symble	Parameter	Min	Typ	Max	Units	Note
VDD	Logic/LCD Drive Voltage	3.0	3.3	3.6	[Volt]	
PDD	VDD Power			2	[Watt]	Note 1
IDD	IDD Current		500	600	[mA]	Note 1
IRush	Inrush Current			2000	[mA]	Note 2
VDDrp	Allowable Logic/LCD Drive Ripple Voltage			100	[mV] p-p	

Note 1 : Maximum Measurement Condition : Black Pattern

Note 2 : Measure Condition

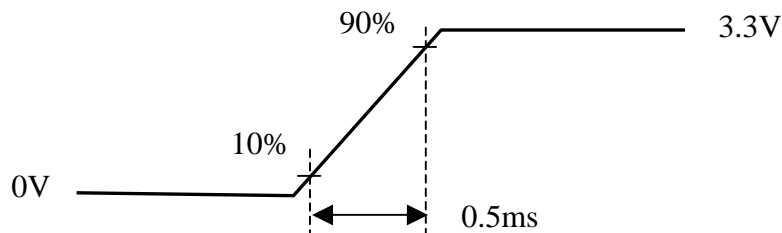
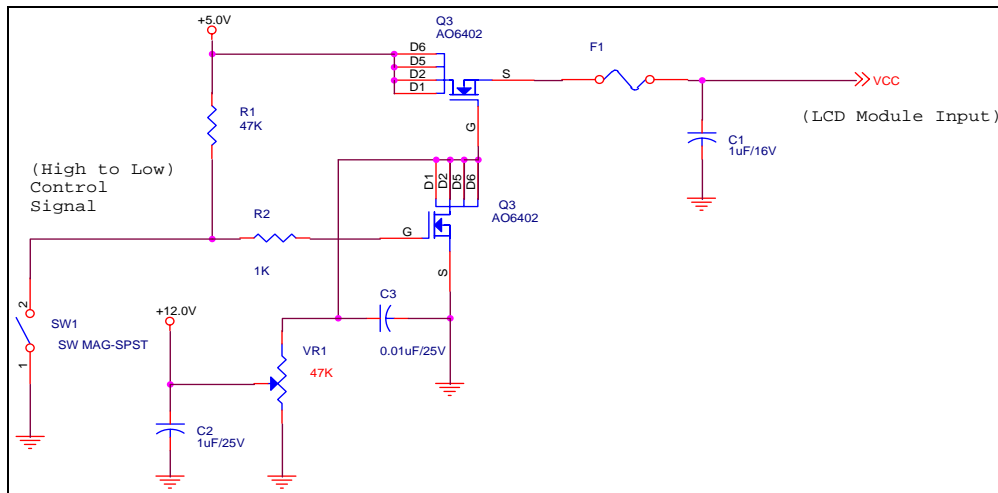

Vin rising time





## 5.2 Backlight Unit

Parameter guideline for CCFL Inverter

Parameter	Min	Typ	Max	Units	Condition
White Luminance 5 points average	-	160	-	[cd/m <sup>2</sup> ]	(Ta=25 )
CCFL current(I <sub>CCFL</sub> )	3.0	6.0	6.5	[mA] rms	(Ta=25 ) Note 2
CCFL Frequency(F <sub>CCFL</sub> )	50	62	70	[KHz]	(Ta=25 ) Note 3,4
CCFL Ignition Voltage(Vs)	1430			[Volt] rms	(Ta= 0 ) Note 5
CCFL Ignition Voltage(Vs)	1190			[Volt] rms	(Ta= 25 ) Note 5
CCFL Voltage (Reference) (V <sub>CCFL</sub> )	648	720	792	[Volt] rms	(Ta=25 ) Note 6
CCFL Power consumption (P <sub>CCFL</sub> )	-	4.30	4.50	[Watt]	(Ta=25 ) Note 6

Note 1: Typ are AUO recommended Design Points.

\*1 All of characteristics listed are measured under the condition using the AUO Test inverter.

\*2 In case of using an inverter other than listed, it is recommended to check the inverter carefully. Sometimes, interfering noise stripes appear on the screen, and substandard luminance or flicker at low power may happen.

\*3 In designing an inverter, it is suggested to check safety circuit very carefully. Impedance of CCFL, for instance, becomes more than 1 [M ohm] when CFL is damaged.

\*4 Generally, CCFL has some amount of delay time after applying kick-off voltage. It is recommended to keep on applying kick-off voltage for 1 [Sec] until discharge.

\*5 CCFL discharge frequency must be carefully chosen so as not to produce interfering noise stripes on the screen.

\*6 Reducing CCFL current increases CCFL discharge voltage and generally increases CCFL discharge frequency. So all the parameters of an inverter should be carefully designed so as not to produce too much leakage current from high-voltage output of the inverter.

Note 2: It should be employed the inverter which has "Duty Dimming", if ICCFL is less than 4mA.

Note 3: CCFL discharge frequency should be carefully determined to avoid interference between inverter and TFT LCD.

Note 4: The frequency range will not affect to lamp life and reliability characteristics.



Note 5: CCFL inverter should be able to give out a power that has a generating capacity of over 1,430 voltage.  
Lamp units need 1,400 voltage minimum for ignition.

Note 6: Calculator value for reference ( $I_{CCFL} \times V_{CCFL} = P_{CCFL}$ )

Note 7: Requirements for a system inverter design, which is intended to have a better display performance, a better power efficiency and a more reliable lamp, are following.

It shall help increase the lamp lifetime and reduce leakage current.

- The asymmetry rate of the inverter waveform should be less than 10%.
- The distortion rate of the waveform should be within  $2 \pm 10\%$ .

\* Inverter output waveform had better be more similar to ideal sine wave.

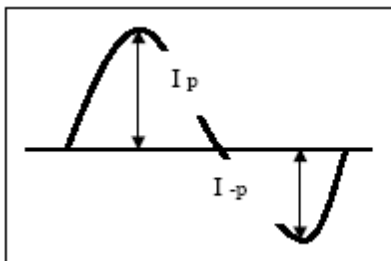

\* Asymmetry rate:

$$\frac{|I_p - I_{-p}|}{I_{rms}} * 100\%$$

\* Distortion rate

$$I_p \text{ (or } I_{-p}) / I_{rms}$$



### 5.3 Inverter Characteristic

Electrical Characteristics :  $V_{in}=7.5V\sim 21V$ ,  $T_a=25$

No.	Item	Symbol	Condition	Min.	Typ.	Max.	Unit
1	Input Voltage	INV_SRC	-	7.5	14.0	21.0	V
2	Input Voltage	5VALW	-	4.85	-	5.20	V
3	Input Current	$I_{in}$	$V_{in}=14.0V$ , max. output	-	0.420	-	A
4	Input Power	$P_{in}$	$V_{in}=14.0V$ , $I_{out}=6.5mA$	-	-	6.20	W
5	Backlight ON/OFF Control <sup>(1)</sup>	ON	Enable the inverter	2.0	-	5.25	V
		OFF	Disable the inverter	-0.3	-	0.8	V
6	SMBus Mode Brightness Adjust	SMB_DAT	Min. output: 00H Max. output: FFH	00	-	FF	Hex.
7	DPST mode (System side PWM input)	PWM(Hz)	-	-	10	-	KHz
		PWM Voltage	-	3.135	3.30	3.465	V
		Signal intensity	-	00	-	FF	Hex
8	Output Voltage	$V_{out}$	Max. output	-	700	-	V <sub>rms</sub>
9	Output Current	$I_{out}$ (Min)	$T_a=25$ , after running 30 min.	1.2	1.5	1.8	mArms
		$I_{out}$ (Max)		6.3	6.5	6.8	mArms
10	Frequency	Freq	Max. output	45	55	65	KHz
11	Output Power	$P_{out}$	$V_{in}=14.0V$ , $I_{out}(\text{Max})$	-	4.96	-	W
12	Burst Mode Frequency	$f_B$		-	200	-	Hz
13	Ambient Light input signal			5	-	1000	Lux
14	Open Lamp Voltage <sup>(2)</sup>	$V_{open}$	No Load	1400	-	-	V <sub>rms</sub>
15	Striking Time	$T_s$	No Load	0.6	1.0	1.4	Sec
16	Efficiency	$\eta$	$V_{in}=7.5V$ , Max. output, Load=100K	-	80	-	%
17	Start -up time			-	-	0.1	Sec





## 6.2 The input data format

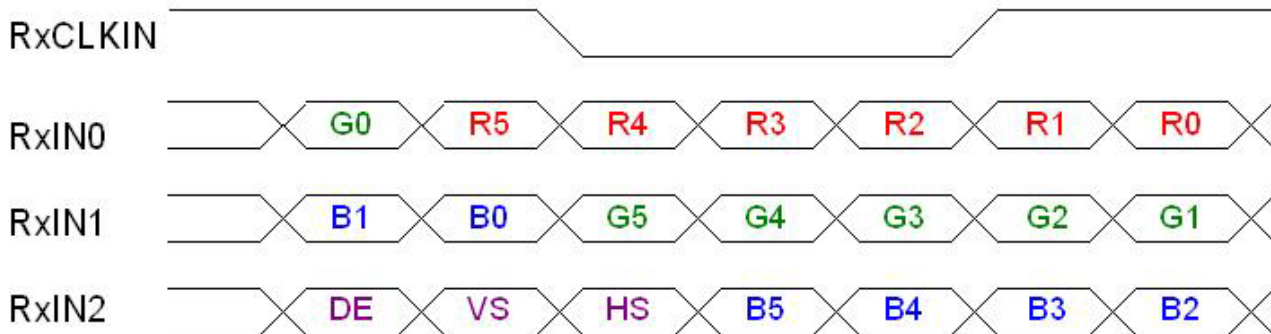

Signal Name	Description	
R5 R4 R3 R2 R1 R0	Red Data 5 (MSB) Red Data 4 Red Data 3 Red Data 2 Red Data 1 Red Data 0 (LSB)	Red-pixel Data Each red pixel's brightness data consists of these 6 bits pixel data.
G5 G4 G3 G2 G1 G0	Green Data 5 (MSB) Green Data 4 Green Data 3 Green Data 2 Green Data 1 Green Data 0 (LSB)	Green-pixel Data Each green pixel's brightness data consists of these 6 bits pixel data.
B5 B4 B3 B2 B1 B0	Blue Data 5 (MSB) Blue Data 4 Blue Data 3 Blue Data 2 Blue Data 1 Blue Data 0 (LSB)	Blue-pixel Data Each blue pixel's brightness data consists of these 6 bits pixel data.
RxCLKIN	Data Clock	The typical frequency is 68.9 MHZ.. The signal is used to strobe the pixel data and DE signals. All pixel data shall be valid at the falling edge when the DE signal is high.
DE	Display Timing	This signal is strobed at the falling edge of RxCLKIN. When the signal is high, the pixel data shall be valid to be displayed.
VS	Vertical Sync	The signal is synchronized to RxCLKIN .
HS	Horizontal Sync	The signal is synchronized to RxCLKIN .

Note: Output signals from any system shall be low or High-impedance state when VDD is off.



### 6.3 Signal Description/Pin Assignment

LVDS is a differential signal technology for LCD interface and high speed data transfer device.

PIN#	Signal Name	Description
1	GND	Ground
2	VDD	+3.3V Power Supply
3	VDD	+3.3V Power Supply
4	V <sub>EDID</sub>	+3.3V EDID Power
5	NC	No Connection (Reserve for AUO test)
6	CLK <sub>EDID</sub>	EDID Clock Input
7	DATA <sub>EDID</sub>	EDID Data Input
8	RxIN0-	LVDS differential data input(R0-R5, G0)
9	RxIN0+	LVDS differential data input(R0-R5, G0)
10	GND	Ground
11	RxIN1-	LVDS differential data input(G1-G5, B0-B1)
12	RxIN1+	LVDS differential data input(G1-G5, B0-B1)
13	GND	Ground
14	RxIN2-	LVDS differential data input(B2-B5, HS, VS, DE)
15	RxIN2+	LVDS differential data input(B2-B5, HS, VS, DE)
16	GND	Ground
17	RxCLKIN-	LVDS differential clock input
18	RxCLKIN+	LVDS differential clock input
19	GND	Ground
20	GND	Ground
21	NC	No Connection (Reserve for AUO test)
22	NC	No Connection (Reserve for AUO test)
23	NC	No Connection (Reserve for AUO test)
24	NC	No Connection (Reserve for AUO test)
25	NC	No Connection (Reserve for AUO test)
26	NC	No Connection (Reserve for AUO test)
27	NC	No Connection (Reserve for AUO test)
28	NC	No Connection (Reserve for AUO test)
29	NC	No Connection (Reserve for AUO test)
30	NC	No Connection (Reserve for AUO test)



Product Specification

Note1: Start from right side

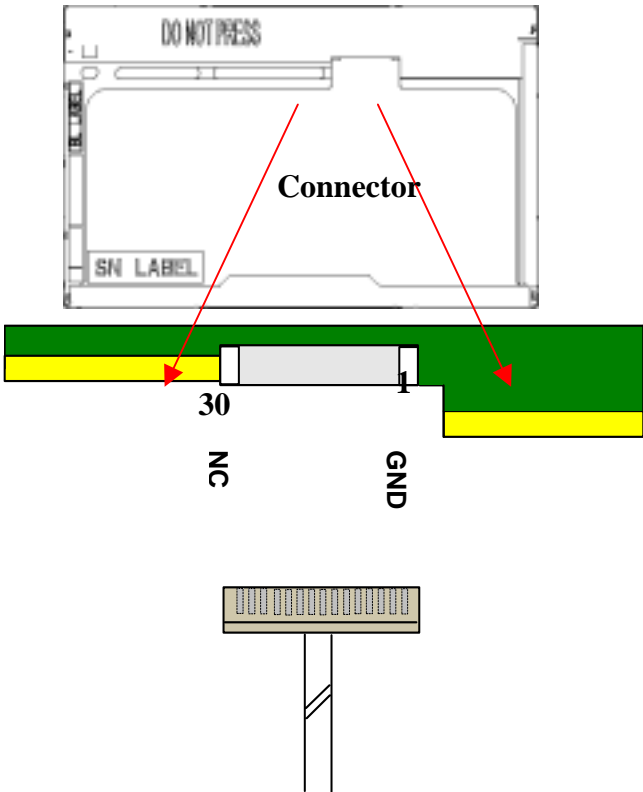

Note2: Input signals shall be low or High-impedance state when VDD is off.  
 internal circuit of LVDS inputs are as following.  
 The module uses a 100ohm resistor between positive and negative data lines of each receiver input

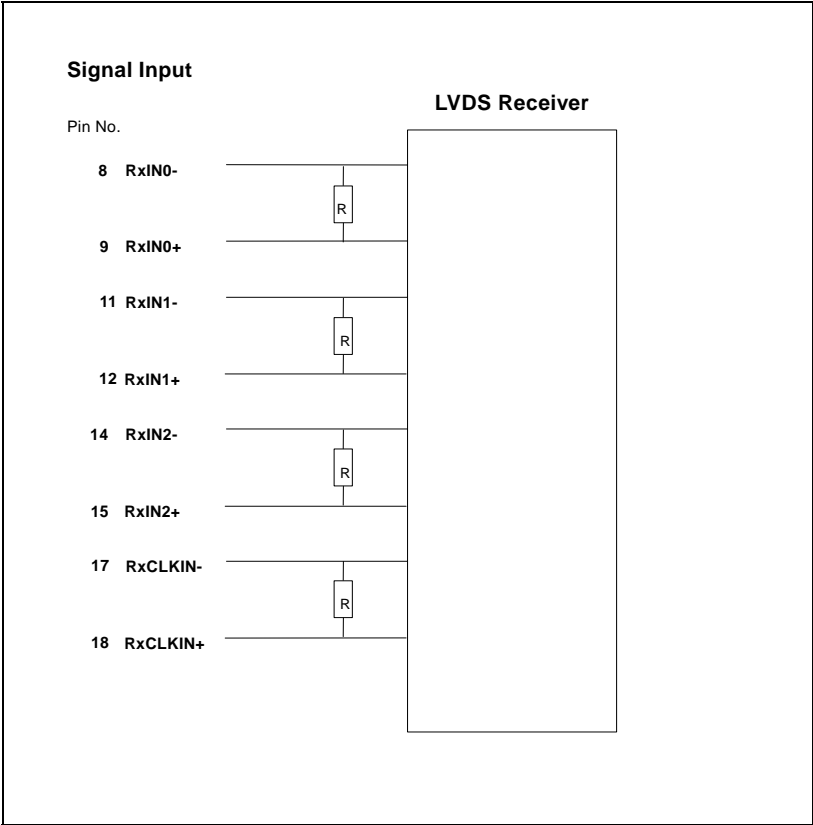



## 6.4 Interface Timing

### 6.4.1 Timing Characteristics

Basically, interface timings should match the 1280x800 /60Hz manufacturing guide line timing.

Parameter		Symbol	Min.	Typ.	Max.	Unit
Frame Rate		-	50	60	-	Hz
Clock frequency		$1/T_{\text{Clock}}$	50	68.9	80	MHz
Vertical Section	Period	$T_V$	803	816	832	$T_{\text{Line}}$
	Active	$T_{VD}$	800	800	800	
	Blanking	$T_{VB}$	3	16	32	
Horizontal Section	Period	$T_H$	1302	1408	1700	$T_{\text{Clock}}$
	Active	$T_{HD}$	-	1280	-	
	Blanking	$T_{HB}$	22	128	420	

Note : DE mode only



6.4.2 Timing diagram

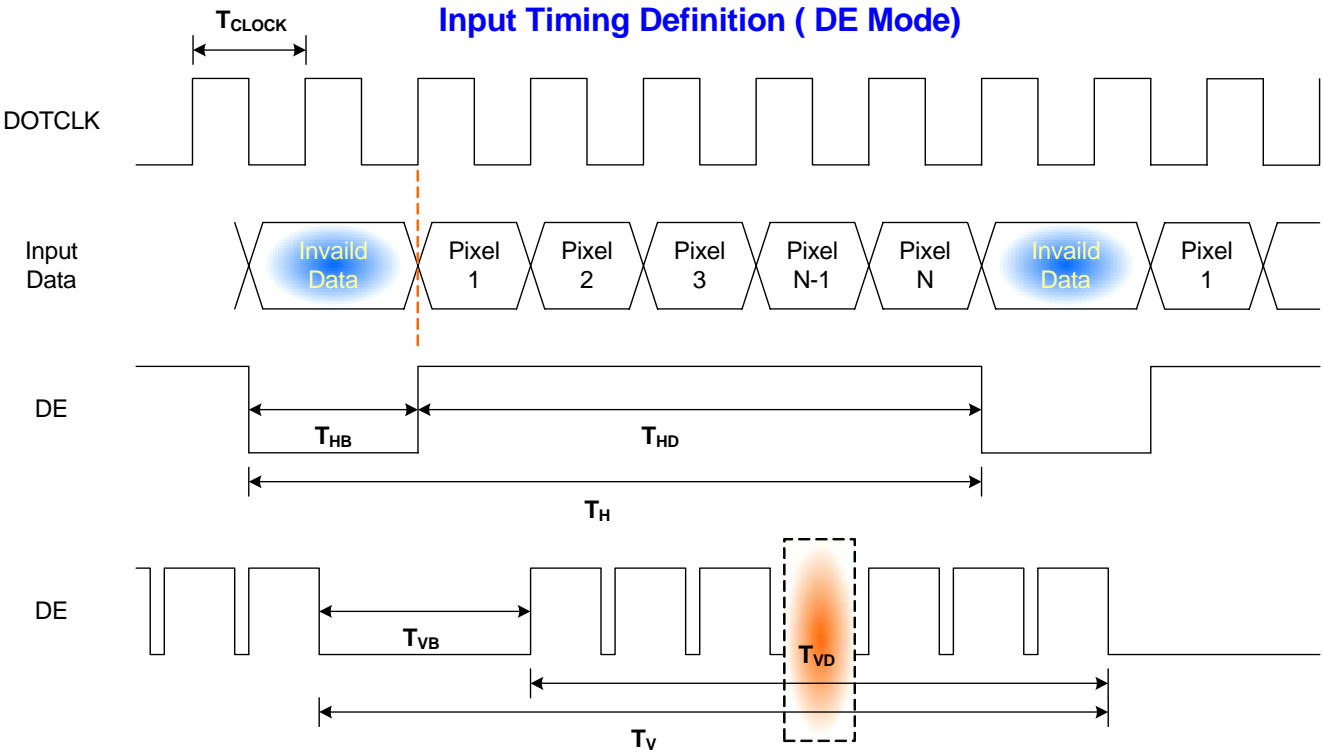



6.5 Power ON/OFF Sequence

VDD power and lamp on/off sequence is as follows. Interface signals are also shown in the chart. Signals from any system shall be Hi-Z state or low level when VDD is off.

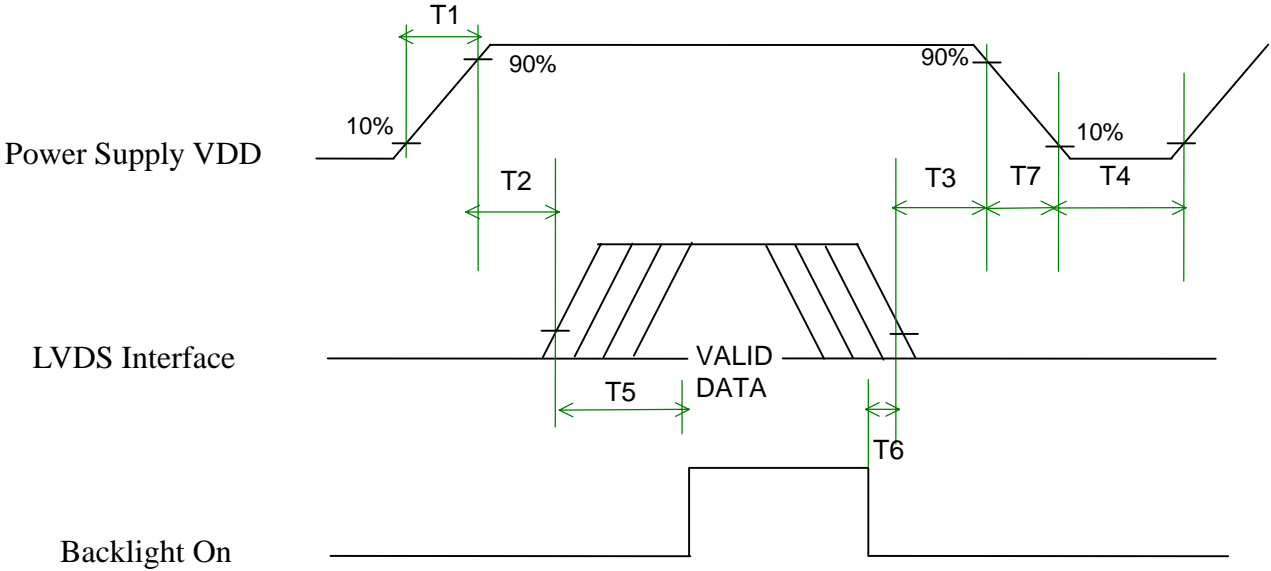

Power Sequence Timing

Parameter	Value			Units
	Min.	Typ.	Max.	
T1	0.5	-	10	(ms)
T2	0	-	50	(ms)
T3	0	-	50	(ms)
T4	400	-	-	(ms)
T5	200	-	-	(ms)
T6	200	-	-	(ms)
T7	0	-	10	(ms)



## 7. Connector Description

Physical interface is described as for the connector on module.

These connectors are capable of accommodating the following signals and will be following components.

### 7.1 TFT LCD Module

Connector Name / Designation	For Signal Connector
Manufacturer	JAE or compatible
Type / Part Number	FI-XB30SL-HF10 or compatible
Mating Housing/Part Number	FI-X30H or compatible

### 7.2 Backlight Unit

Physical interface is described as for the connector on module.

These connectors are capable of accommodating the following signals and will be following components.

Connector Name / Designation	For Lamp Connector
Manufacturer	JST
Type / Part Number	BHSR-02VS-1
Mating Type / Part Number	SM02B-BHSS-1-TB

### 7.3 Signal for Lamp connector

Pin #	Cable color	Signal Name
1	Red	Lamp High Voltage
2	White	Lamp Low Voltage



## 8. Vibration and Shock Test (Stand alone)

### 8.1 Vibration Test

#### Test Spec:

- Test method: Non-Operation
- Acceleration: 1.3G
- Frequency: 10 - 500Hz Random
- Sweep: 30 Minutes each Axis (X, Y, Z)

### 8.2 Shock Test Spec:

#### Test Spec:

- Test method: Non-Operation
- Acceleration: 220 G , Half sine wave
- Active time: 2 ms
- Pulse: X,Y,Z .one time for each side



## 9. Reliability

Items	Required Condition	Note
Temperature Humidity Bias	40 /95%,250Hr	
High Temperature Operation	65 /Dry,250Hr	
Low Temperature Operation	0 ,300Hr	
On/Off Test	25 ,150hrs(ON/10 sec. OFF/10sec., 10,000 cycles)	
Hot Storage	65 /20% RH ,250 hours	
Cold Storage	-40 /50% RH ,250 hours	
Thermal Shock Test	-40 /30 min ,65 /30 min 100cycles	
Hot Start Test	50 /1 Hr min. power on/off per 5 minutes, 5 times	
Cold Start Test	0 /1 Hr min. power on/off per 5 minutes, 5 times	
Shock Test (Non-Operating)	220G, 2ms, Half-sine wave	
Vibration Test (Non-Operating)	Random vibration, 1.3 G zero-to-peak, 10 to 500 Hz, 30 mins in each of three mutually perpendicular axes.	
ESD	Contact : ±8KV/ operation Air : ±15KV / operation	Note 1
Room temperature Test	25 , 2000hours, Operating with loop pattern	

Note1: According to EN61000-4-2 , ESD class B: Some performance degradation allowed. No data lost  
. Self-recoverable. No hardware failures.

Note2: CCFL Life time: 10,000 hours minimum under normal module usage.

Note3: MTBF (Excluding the CCFL): 30,000 hours with a confidence level 90%

# 10. Mechanical Characteristics

## 10.1 LCM Outline Dimension

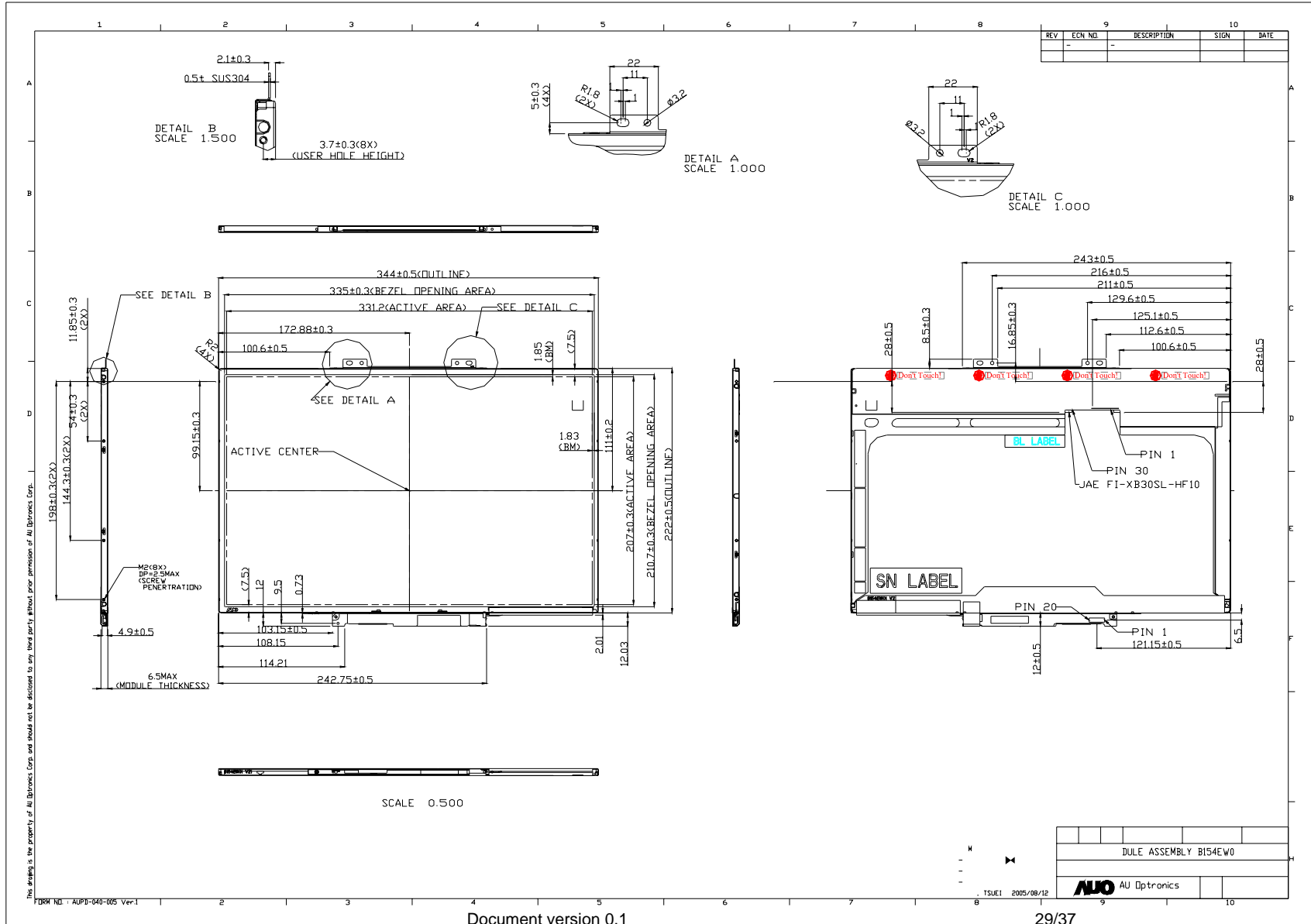

## 10.2 Screw Hole Depth and Center Position

Screw hole minimum depth, from side surface =2.5 mm (See drawing)

Screw hole center location, from front surface =  $3.7 \pm 0.2$ mm (See drawing)

Screw Torque: Maximum 2.5 kgf-cm

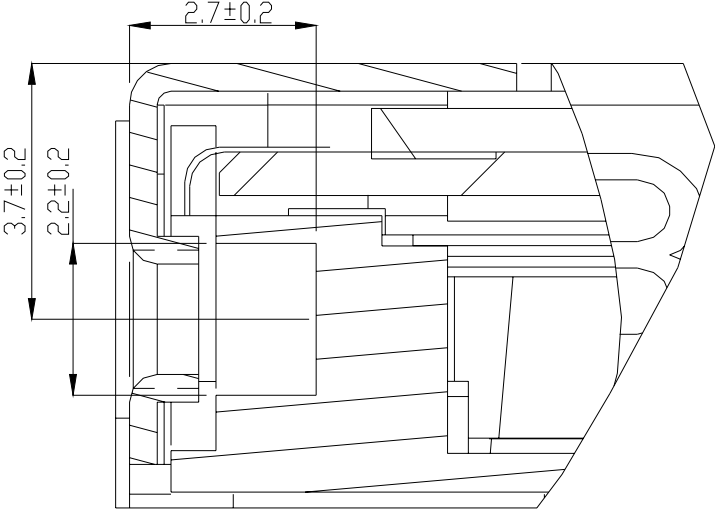

# 11. Shipping and Package

## 11.1 Shipping Label Format

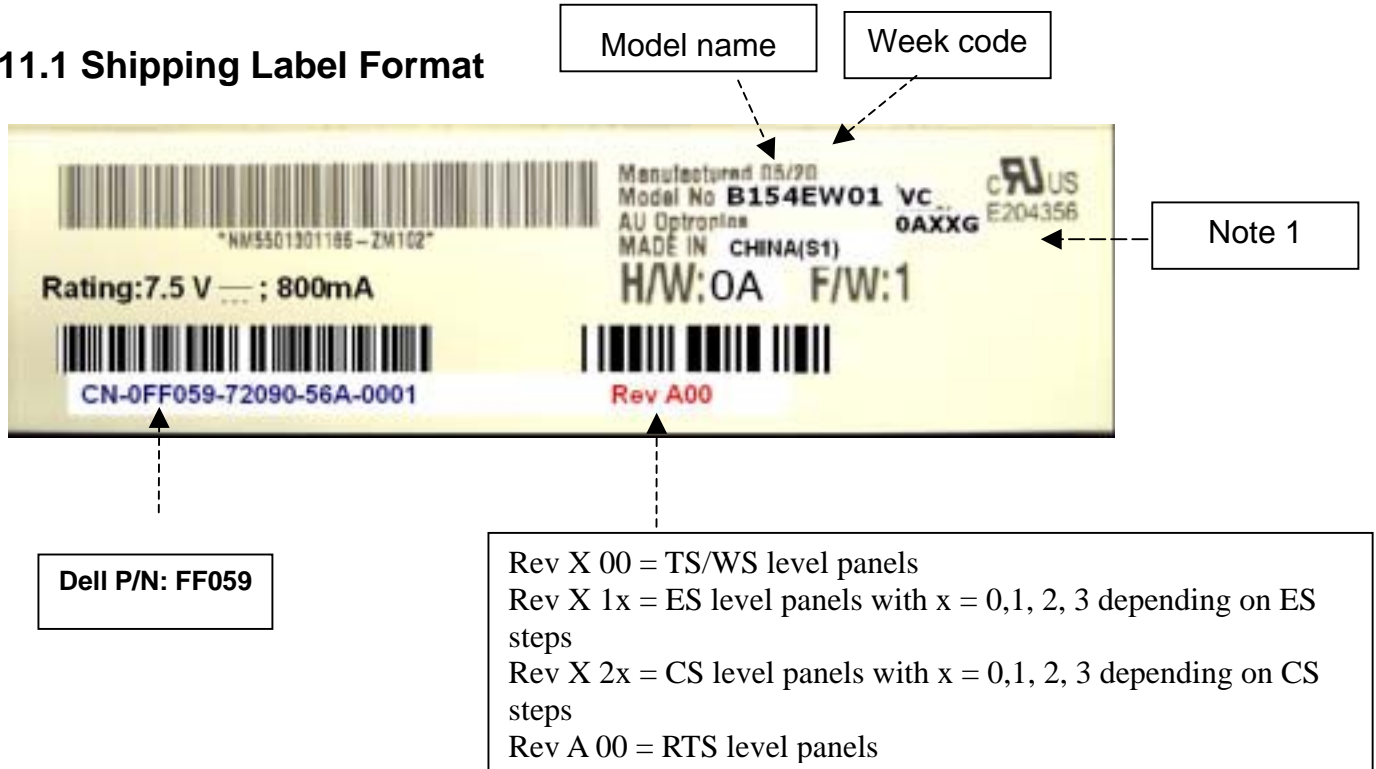

Note 1:

IC Combination	Control Code	H/W
Source NT 39360 Gate IC: NT 3959C	0AXXG	0A

## 11.2. Carton package

The outside dimension of carton is 455 (L)mm x 380 (W)mm x 355 (H)mm

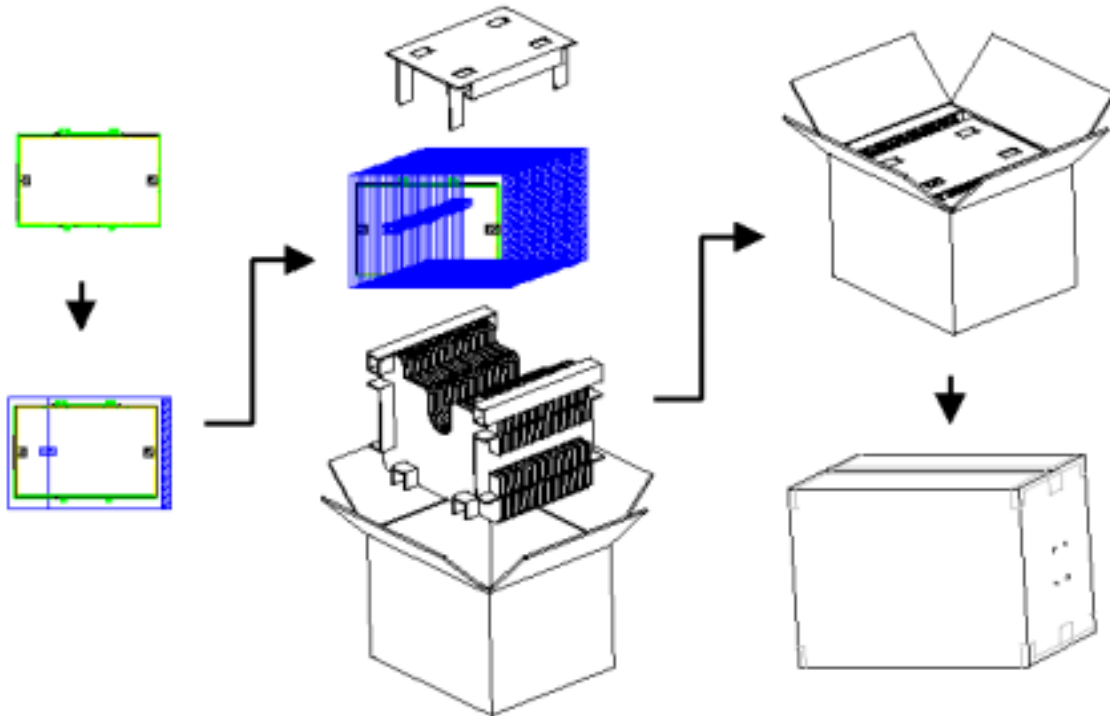

## 11.3 Shipping package of palletizing sequence

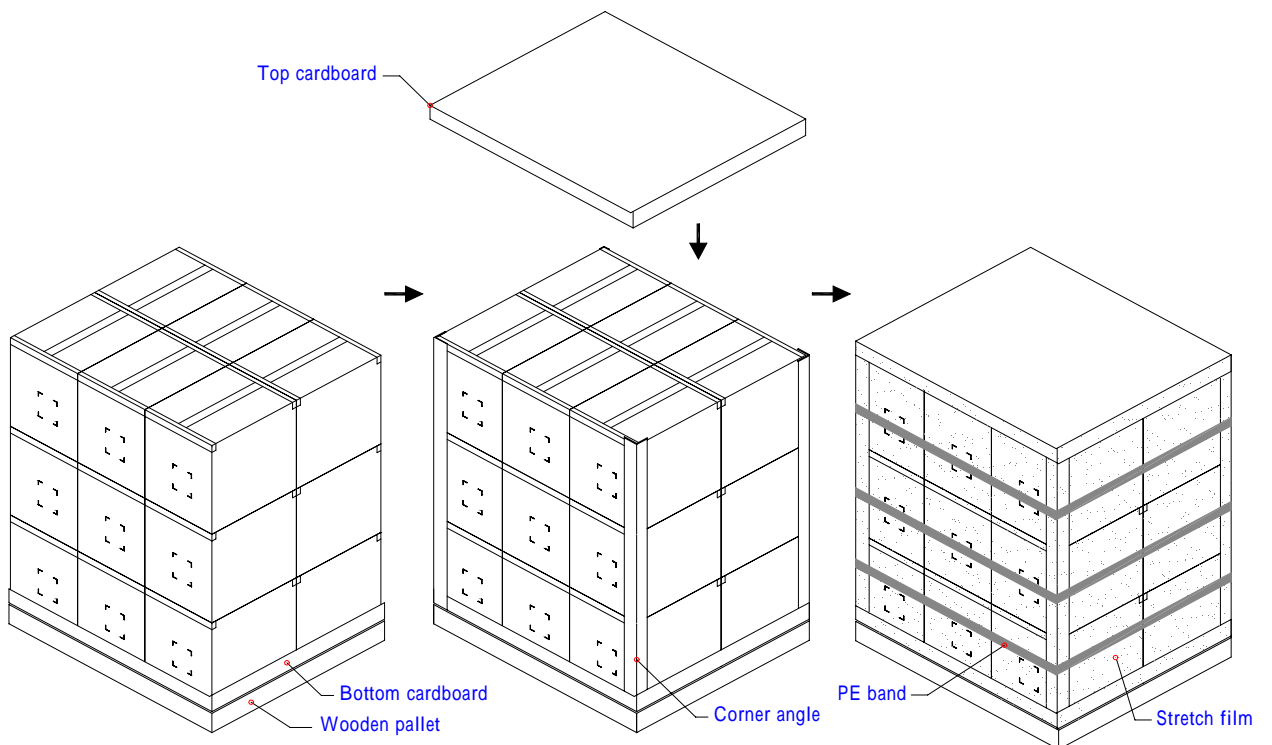

Note : Limit of box palletizing = Max 3 layers(ship and stock conditions)

## 12. Appendix: EDID description

B154EW01 VC(Foxconn) EDID Table					
	Byte	Field Name and Comments	Value	Value	Value
	(hex)		(Hex)	(Binary)	(DEC)
Header	0	Header	00	00000000	0
	1	Header	FF	11111111	255
	2	Header	FF	11111111	255
	3	Header	FF	11111111	255
	4	Header	FF	11111111	255
	5	Header	FF	11111111	255
	6	Header	FF	11111111	255
	7	Header	00	00000000	0
Vendor / Product EDID Version	8	EISA manufacture code = 3 Character ID	06	00000110	6
	9	EISA manufacture code (Compressed ASCII)	AF	10101111	175
	0A	Panel Supplier Reserved – Product Code	74	01110100	116
	0B	Panel Supplier Reserved – Product Code	1C	00011100	28
	0C	LCD module Serial No - Preferred but Optional (“0” if not used)	00	00000000	0
	0D	LCD module Serial No - Preferred but Optional (“0” if not used)	00	00000000	0
	0E	LCD module Serial No - Preferred but Optional (“0” if not used)	00	00000000	0
	0F	LCD module Serial No - Preferred but Optional (“0” if not used)	00	00000000	0
	10	Week of manufacture	01	00000001	1
	11	Year of manufacture	0F	00001111	15
	12	EDID structure version # = 1	01	00000001	1
	13	EDID revision # = 3	03	00000011	3
	Display Parameters	14	Video I/P definition = Digital I/P (80h)	80	10000000
15		Max H image size = (Rounded to cm)	21	00100001	33
16		Max V image size = (Rounded to cm)	15	00010101	21
17		Display gamma = (gamma ×100)-100 = Example: ( 2.2×100 ) – 100 = 120	78	01111000	120
18		Feature support ( no DPMS, Active off, RGB, timing BLK 1)	0A	00001010	10
Panel Color Coordinates	19	Red/Green Low bit (RxRy/GxGy)	A7	10100111	167
	1A	Blue/White Low bit (BxBY/WxWy)	E5	11100101	229
	1B	Red X	99	10011001	153
	1C	Red Y	59	01011001	89
	1D	Green X	4F	01001111	79
	1E	Green Y	8C	10001100	140
	1F	Blue X	27	00100111	39
	20	Blue Y	1D	00011101	29
	21	White X	50	01010000	80

Established Timings	22	White Y	54	01010100	84
	23	Established timings 1 (00h if not used)	00	00000000	0
	24	Established timings 2 (00h if not used)	00	00000000	0
	25	Manufacturer's timings (00h if not used)	00	00000000	0
Standard Timing ID	26	Standard timing ID1 (01h if not used)	01	00000001	1
	27	Standard timing ID1 (01h if not used)	01	00000001	1
	28	Standard timing ID2 (01h if not used)	01	00000001	1
	29	Standard timing ID2 (01h if not used)	01	00000001	1
	2A	Standard timing ID3 (01h if not used)	01	00000001	1
	2B	Standard timing ID3 (01h if not used)	01	00000001	1
	2C	Standard timing ID4 (01h if not used)	01	00000001	1
	2D	Standard timing ID4 (01h if not used)	01	00000001	1
	2E	Standard timing ID5 (01h if not used)	01	00000001	1
	2F	Standard timing ID5 (01h if not used)	01	00000001	1
	30	Standard timing ID6 (01h if not used)	01	00000001	1
	31	Standard timing ID6 (01h if not used)	01	00000001	1
	32	Standard timing ID7 (01h if not used)	01	00000001	1
	33	Standard timing ID7 (01h if not used)	01	00000001	1
34	Standard timing ID8 (01h if not used)	01	00000001	1	
35	Standard timing ID8 (01h if not used)	01	00000001	1	
Timing Descriptor #1	36	Pixel Clock/10,000 (LSB)	C7	11000111	199
	37	Pixel Clock/10,000 (MSB)	1B	00011011	27
	38	Horizontal Active (lower 8 bits)	00	00000000	0
	39	Horizontal Blanking (Thbp) (lower 8 bits)	A0	10100000	160
	3A	Horizontal Active/Horizontal blanking (Thbp) (upper 4:4 bits)	50	01010000	80
	3B	Vertical Active	20	00100000	32
	3C	Vertical Blanking (Tvbp) (DE Blanking typ. for DE only panels)	17	00010111	23
	3D	Vertical Active : Vertical Blanking (Tvbp) (upper 4:4 bits)	30	00110000	48
	3E	Horizontal Sync, Offset (Thfp)	15	00010101	21
	3F	Horizontal Sync, Pulse Width	20	00100000	32
	40	Vertical Sync, Offset (Tvfp) Sync Width	44	01000100	68
	41	Horizontal Vertical Sync Offset/Width upper 2 bits	00	00000000	0
	42	Horizontal Image Size	4B	01001011	75
	43	Vertical image Size	CF	11001111	207
44	Horizontal Image Size / Vertical image size	10	00010000	16	
45	Horizontal Border = 0 (Zero for Notebook LCD)	00	00000000	0	

	46	Vertical Border = 0 (Zero for Notebook LCD)	00	00000000	0	
		Non-interlaced, Normal, no stereo, Separate sync, H/V pol Negatives, <b>DE only note: LSB is set to "1" if panel is DE-timing only. H/V can be ignored.</b>	18	00011000	24	
Timing Descriptor #2	48	Pixel Clock/10,000 (LSB)	26	00100110	38	
	49	Pixel Clock/10,000 (MSB)	17	00010111	23	
	4A	Horizontal Active = xxxx pixels (lower 8 bits)	00	00000000	0	
	4B	Horizontal Blanking (Thbp) = xxxx pixels (lower 8 bits)	A0	10100000	160	
	4C	Horizontal Active/Horizontal blanking (Thbp) (upper4:4 bits)	50	01010000	80	
	4D	Vertical Active = xxxx lines	20	00100000	32	
	4E	Vertical Blanking (Tvbp) = xxxx lines (DE Blanking typ. for DE only panels)	17	00010111	23	
	4F	Vertical Active : Vertical Blanking (Tvbp) (upper4:4 bits)	30	00110000	48	
	50	Horizontal Sync, Offset (Thfp) = xxxx pixels	15	00010101	21	
	51	Horizontal Sync, Pulse Width = xxxx pixels	20	00100000	32	
	52	Vertical Sync, Offset (Tvfp) = xx lines Sync Width = xx lines	44	01000100	68	
	53	Horizontal Vertical Sync Offset/Width upper 2 bits	00	00000000	0	
	54	Horizontal Image Size = xxx mm	4B	01001011	75	
	55	Vertical image Size = xxx mm	CF	11001111	207	
	56	Horizontal Image Size / Vertical image size	10	00010000	16	
	57	Horizontal Border = 0 (Zero for Notebook LCD)	00	00000000	0	
	58	Vertical Border = 0 (Zero for Notebook LCD)	00	00000000	0	
	59	Module "A" Revision = Example: 00, 01, 02, 03, etc.	00	00000000	0	
	Timing Descriptor #3 Dell specific information	5A	Flag	00	00000000	0
		5B	Flag	00	00000000	0
5C		Flag	00	00000000	0	
5D		Dummy Descriptor	FE	11111110	254	
5E		Flag	00	00000000	0	
5F		Dell P/N 1 <sup>st</sup> Character	46	01000110	70	
60		Dell P/N 2 <sup>nd</sup> Character	46	01000110	70	
61		Dell P/N 3 <sup>rd</sup> Character	30	00110000	48	
62		Dell P/N 4 <sup>th</sup> Character	35	00110101	53	
63		Dell P/N 5 <sup>th</sup> Character	39	00111001	57	
64	LCD Supplier EEDID Revision #	00	00000000	0		

	65	Manufacturer P/N	42	01000010	66
	66	Manufacturer P/N	31	00110001	49
	67	Manufacturer P/N	35	00110101	53
	68	Manufacturer P/N	34	00110100	52
	69	Manufacturer P/N	45	01000101	69
	6A	Manufacturer P/N	57	01010111	87
		Manufacturer P/N (If <13 char, then terminate with ASCII code 0Ah, set remaining char = 20h)	31	00110001	49
Timing Descriptor #4	6C	Flag	00	00000000	0
	6D	Flag	00	00000000	0
	6E	Flag	00	00000000	0
	6F	Data Type Tag:	FE	11111110	254
	70	Flag	00	00000000	0
	71	SMBUS Value	30	00110000	48
	72	SMBUS Value	41	01000001	65
	73	SMBUS Value	4D	01001101	77
	74	SMBUS Value	57	01010111	87
	75	SMBUS Value	78	01111000	120
	76	SMBUS Value	A4	10100100	164
	77	SMBUS Value	CC	11001100	204
	78	SMBUS Value = max nits (Typically = 00h)	F8	11111000	248
	79	Number of LVDS receiver chips = '01' or '02'	01	00000001	1
	7A	BIST Enable: Yes = '01' No = '00'	01	00000001	1
	7B	(If <13 char, then terminate with ASCII code 0Ah, set remaining char = 20h)	0A	00001010	10
7C	(If <13 char, then terminate with ASCII code 0Ah, set remaining char = 20h)	20	00100000	32	
7D	(If <13 char, then terminate with ASCII code 0Ah, set remaining char = 20h)	20	00100000	32	
Checksum	7E	Extension flag (# of optional 128 EDID extension blocks to follow, Typ = 0)	00	00000000	0
	7F	Checksum (The 1-byte sum of all 128 bytes in this EDID block shall = 0)	E9	11101001	233

